

MAGNUM

TM



**MATERIAL HANDLING
& WORK PLATFORMS
CATALOG**

TM

MAGNUM

SINCE 1989

In 1989, Magnum Tool Corp, Inc. began its journey as a tool distributor in our hometown of Houston, Texas. Aiming to build a lasting imprint on our community, we focused on establishing a reputation for delivering professional-grade tools and equipment at exceptional value. We are blessed and proud of the company we've built with the support of our community, our great team, the network of distribution we have cultivated, and the many loyal contractors that use our tools and equipment worldwide.

Today, Magnum offers a great selection of Material Handling Equipment, Drywall Specific Tools and Material, Step-Up Benches, Fasteners, and more. We continue to innovate and add value to the products we develop and carry. Magnum products are engineered to excel with rugged daily use. Whether it's a dump cart tub that tilts easily, maneuvers through narrow passages, and still transports efficiently, or the latest in drywall cart design; Magnum provides professional-grade equipment to keep you moving.

Our product line encompasses a wide offering to support residential, commercial, industrial, and general construction. Tradespeople, such as acoustical contractors, electricians, drywall contractors, janitors, and facilities workers are at the core of our loyal user base. Our commitment to excel through friendly and knowledgeable customer service, product training, and support, is what sets Magnum apart. Our devoted team works in tandem to ensure your satisfaction.

Welcome to the family!

VISIT MAGNUM-TOOL.COM



MATERIAL HANDLING



<i>DUMP CARTS & ACCESSORIES</i>	6-9
<i>TRASH CANS & ACCESSORIES</i>	10-11
<i>MATERIAL CARTS & ACCESSORIES</i>	12-17
<i>UTILITY/SERVICE CARTS & VAULT</i>	18-25
<i>WHEELBARROWS, PARTS & ACCESSORIES</i>	26-27
<i>CASTERS & TIRES</i>	28-29
FIREBOX™	30



WORK PLATFORMS

<i>STEP-UP BENCHES</i>	32-33
<i>SCAFFOLD & ACCESSORIES</i>	34



**JOBSITE
READY**

MATERIAL HANDLING

Our products are designed to work as hard as you. They carry their weight and perform on the daily. Moving material, moving your job forward, and making it happen.





DUMP CARTS



MATERIAL CARTS



SERVICE CARTS



MAGNUM

MATERIAL HANDLING



MAGNUM™

Save freight and space by stacking more on a pallet.

- Premium injection molded tubs for added strength in corners
- Smooth surface is easy to clean and resists corrosion
- Fits through standard doorways and elevators
- Handling can be performed by a single user
- Construction grade wheels and casters

1/2 Cubic Yard Dump Cart



750 LB LOAD CAPACITY

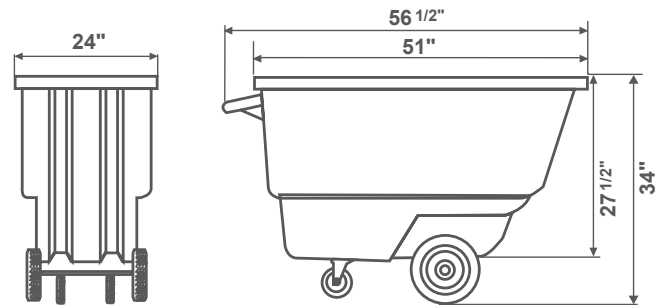

ITEM CODE	CASTER TYPE	WHEEL TYPE	ITEM WEIGHT	PALLET COUNT
DUC12T	4" HEAVY-DUTY	10" HEAVY-DUTY	64 LB	14
DUC12T-NM*	5" NON-MARKING	12" NON-MARKING	48 LB	14

*Use 2-5/8" Axle (DUA12-575)

1 Cubic Yard Covered Capacity Dump Cart



800 LB LOAD CAPACITY

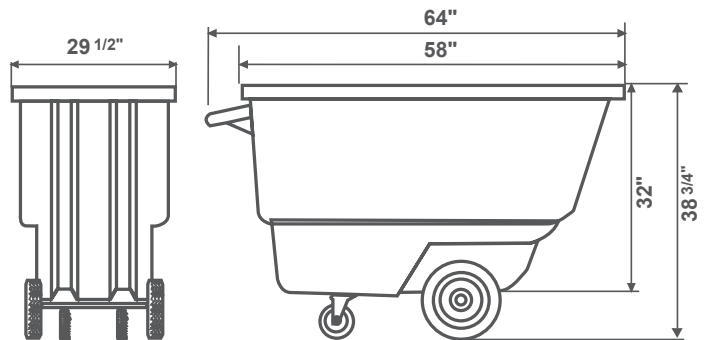

ITEM CODE	CASTER TYPE	WHEEL TYPE	ITEM WEIGHT	PALLET COUNT
DUC100-12	5" HEAVY-DUTY	12" HEAVY-DUTY	89 LB	12
DUC100-12-NM	5" NON-MARKING	12" NON-MARKING	73 LB	12



**1 Cubic Yard Covered Capacity Dump Cart w/
Reinforcing Frame**

UP TO 1000 LB LOAD CAPACITY

ITEM CODE	CASTER TYPE	WHEEL TYPE	LOAD CAPACITY	ITEM WEIGHT	PALLET COUNT
DUC100-R	5" HEAVY-DUTY	12" HEAVY-DUTY	1000 LB	94 LB	12
DUC100-R-NM	5" NON-MARKING	12" NON-MARKING	900 LB	78 LB	12



**1 Cubic Yard Covered Capacity Dump Cart w/
Heavy-Duty Full Frame**

UP TO 1200 LB LOAD CAPACITY

ITEM CODE	CASTER TYPE	WHEEL TYPE	LOAD CAPACITY	ITEM WEIGHT	PALLET COUNT
DUC100-H	5" HEAVY-DUTY	12" HEAVY-DUTY	1200 LB	112 LB	10
DUC100-H-NM	5" NON-MARKING	12" NON-MARKING	950 LB	96 LB	10



**UP TO
1250 LB LOAD CAPACITY**

Same sizes as our other Dump Carts yet compatible with forklifts and automated lifters due to the heavy-duty forklift ready frame.



**MAGNUM HEAVY-DUTY
FORKLIFT READY DUMP CARTS**

ITEM CODE	DESCRIPTION	LOAD CAPACITY	CASTER TYPE	WHEEL TYPE	ITEM WEIGHT	PALLET COUNT
DUC12T-F	1/2 CU. YD. FORK LIFT READY DUMP CART, HD	850 LB	5" HEAVY-DUTY	12" HEAVY-DUTY	79 LB	8
DUC12T-F-NM	1/2 CU. YD. FORK LIFT READY DUMP CART, NM	850 LB	5" NON-MARKING	12" NON-MARKING	63 LB	8
DUC100-F	1 CU. YD. COVERED CAPACITY FORKLIFT READY DUMP CART, HD	1250 LB	5" HEAVY-DUTY	12" HEAVY-DUTY	103 LB	7
DUC100-F-NM	1 CU. YD. COVERED CAPACITY FORKLIFT READY DUMP CART, NM	1000 LB	5" NON-MARKING	12" NON-MARKING	87 LB	7



DUMP CART FRAMES

MATERIAL HANDLING

DUF100R

Reinforcing Frame for 1 Cubic Yard Covered Capacity Dump Cart

Add to any existing 1 CU. YD. Covered Capacity Dump Cart. No additional hardware needed.



ITEM WEIGHT
5 LB

PURCHASE UNIT
1 FRAME

Premium steel powder coated frames resist corrosion.

DUF100H

Heavy Duty Frame for 1 Cubic Yard Covered Capacity Dump Cart

Add to any existing 1 CU. YD. Covered Capacity Dump Cart. No additional hardware needed.



ITEM WEIGHT
23 LB

PURCHASE UNIT
1 FRAME

DUF12F-K

Forklift Ready Frame Kit for 1/2 Cubic Yard Dump Cart

Includes: (1) Forklift Ready Frame, (2) Heavy-Duty 5" Casters, (2) Heavy-Duty 12" Wheels and (1) DUA12-575 Axle.



ITEM WEIGHT
18 LB

PURCHASE UNIT
1 FRAME

DUF100F

Forklift Ready Frame for 1 Cubic Yard Covered Capacity Dump Cart

Add to any existing 1 CU. YD. Covered Capacity Dump Cart. No additional hardware needed.



ITEM WEIGHT
21 LB

PURCHASE UNIT
1 FRAME

DUMP CART LIDS & ACCESSORIES

DUMP CART FABRIC LIDS



DUL12T-F

Soft Fabric Lid for Magnum 1/2 Cubic Yard Dump Cart

DIMENSIONS 51" X 29" X 6.75"
ITEM WEIGHT 3.50 LB

DUL-F

Universal Soft Fabric Lid for 1 Cubic Yard Covered Capacity Dump Cart

DIMENSIONS 67" X 29" X 6.75"
ITEM WEIGHT 3.75 LB

DUL100-F

Soft Fabric Lid for Magnum 1 Cubic Yard Covered Capacity Dump Cart

DIMENSIONS 55" X 29" X 6.75"
ITEM WEIGHT 3.70 LB



DUMP CART PLASTIC LIDS

Plastic Lid for 1/2 Cubic Yard Dump Cart

DUL12T

ITEM WEIGHT	12 LB
PURCHASE UNIT	1 LID

Plastic Lid for 1 Cubic Yard Covered Capacity Dump Cart

DUL100

ITEM WEIGHT	17 LB
PURCHASE UNIT	1 LID

DUMP CART AXLES



ITEM CODE	WORKS WITH	AXLE LENGTH	WEIGHT	BOX COUNT	PURCHASE UNIT
DUA12-550	1/2 CU. YD. CART	21-5/8"	3 LB	1	1 AXLE
DUA12-575*	1/2 CU. YD. CART	22-5/8"	3.3 LB	1	1 AXLE
DUA100-12	1 CU. YD. COVERED CAPACITY CART	24-3/8"	4 LB	1	1 AXLE

*Use this axle on 1/2 cubic yard dump carts (DUC12T-NM and DUC12T-F) when using 5" non-marking casters (CAS5PS-NM) & 12" non-marking wheels (CAS12-NM).

DUMP CART PLATE CASTERS



ITEM CODE	CASTER TYPE	WHEEL DIAMETER	WHEEL WIDTH	WEIGHT	BOX COUNT	PURCHASE UNIT
CAS4PS	HEAVY-DUTY	4"	2"	4 LB	20	1 CASTER
CAS5PS	HEAVY-DUTY	5"	2"	4.6 LB	10	1 CASTER
CAS5PS-NM	NON-MARKING	5"	2"	4.2 LB	10	1 CASTER

DUMP CART WHEELS



ITEM CODE	WHEEL TYPE	WHEEL DIAMETER	WHEEL WIDTH	WEIGHT	BOX COUNT	PURCHASE UNIT
CAS10	HEAVY-DUTY	10"	2-3/4"	7 LB	2	1 WHEEL
CAS12	HEAVY-DUTY	12"	3"	11 LB	2	1 WHEEL
CAS12-NM	NON-MARKING	12"	3"	3 LB	2	1 WHEEL



MAXIMIZE

AIRFLOW

PRO SERIES



PRO SERIES
MAGNUM PRO
SERIES 55 GALLON
TRASH CAN

Excellent quality, innovative features and outstanding value without sacrificing durability. Welcome to Pro Series - professional grade equipment that works hard and stands up to daily punishment.

- Air channels reduce suction and make bag removal a breeze
- Built-in bag cinches to secure liner
- Massively reinforced, jobsite ready trash cans
- Ergonomic built-in handles for comfort and easy handling
- Lids and dollies available as optional accessories



AIR CHANNELS ▲
 make removing bags and unstacking trash cans a breeze, not a challenge.



BAG CINCHES
 help secure your bag and reduce clean up of cans.



MASSIVE REINFORCEMENT
 for added strength and durability.

ITEM CODE	DESCRIPTION	DIMENSIONS	ITEM WEIGHT	PALLET COUNT	PURCHASE UNIT
CMTC-C-44G	PRO SERIES 44 GALLON TRASH CAN - COMING SOON!	27.7" X 24" X 31"	11.6 LB	48	1 TRASH CAN
CMTC-C-55G	PRO SERIES 55 GALLON TRASH CAN	28.8" X 26" X 32.3"	15.2 LB	48	1 TRASH CAN

MAGNUM 32 & 44 GALLON TRASH CANS

- Ergonomic built-in handles for comfort and easy handling
- Lids and dollies available as optional accessories



ITEM CODE	DESCRIPTION	WEIGHT	PALLET COUNT	PURCHASE UNIT
CATC-C-32G	32 GALLON TRASH CAN	9 LB	44	1 TRASH CAN

*Item shown with optional tight snap-on lid, and durable 5-caster rolling dolly. See below.

Put a lid on it and keep it rollin' smooth and hassle-free.

TRASH CAN ACCESSORIES

TRASH CAN LIDS

Our lids fit great, snap shut securely and open easily.



ITEM CODE	DESCRIPTION	WEIGHT	BOX COUNT	PURCHASE UNIT
CATC-L-32G	32 GALLON LID	2 LB	10	1 LID
CMTC-L-44G*	44 GALLON LID (FITS CATC-C-44G & CMTC-C-44G)	2 LB	10	1 LID
CMTC-L-55G**	55 GALLON LID (FITS CMTC-C-55G)	3.2 LB	10	1 LID

* Also fits Rubbermaid Brute 44 gallon trash cans

** Also fits Rubbermaid Brute 55 gallon trash cans

TRASH CAN DOLLIES

Universal Trash Can Dolly. Designed with massive structural reinforcements for improved longevity and transportation of heavy refuse. Fits all Magnum Trash Cans and most other major brands.



Smooth rolling, non-marking casters

ITEM CODE	DESCRIPTION	WEIGHT	BOX COUNT	PURCHASE UNIT
CATC-DG-HD	HEAVY DUTY 20/32/44/55G TRASH CAN DOLLY	6.9 LB	6	1 DOLLY



MATERIAL HANDLING

PRO SERIES

COMMERCIAL DRYWALL CART

Commercial grade, high-capacity cart that handles 3,200 lb loads. The extra-large, sloped deck manages heavy materials while reducing the risk of slipping and tipping. The welded steel cart frame has a powder coat finish that guards against corrosion and withstands the elements. Magnum also offers a variety of compatible casters that meet the needs of any demanding environment.

- 40" x 12" Steel Plate
- High quality powder coated finish
- Available in four different caster configurations to meet virtually any demand
- Configuration shown: Max-Performance Casters
2 swivel casters & 2 swivel casters w/ locks (DOA3200-MP)



Shown w/
8" Max-Performance
Casters w/ Locks

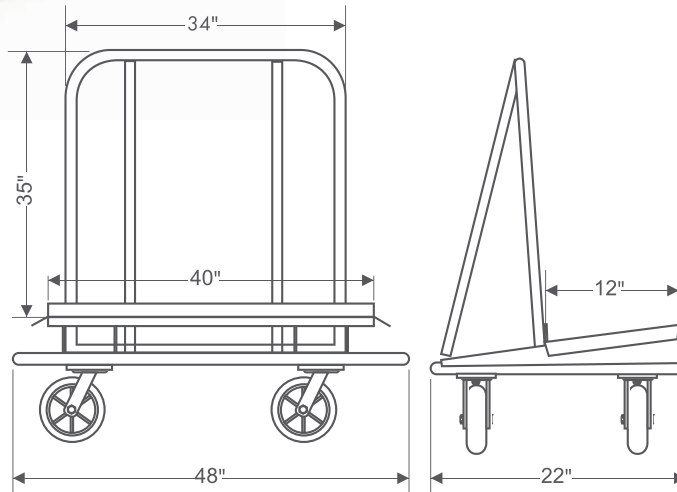

CASTER OPTIONS



8" Max-Performance Polyurethane Casters w/ Locks & Brakes



8" Max-Endurance Polyurethane Casters

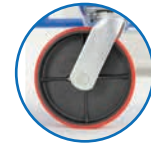

8" Standard Polyurethane Casters

ITEM CODE

DESCRIPTION

LOAD CAPACITY

WEIGHT

PALLET COUNT

PURCHASE UNIT

DOA3200-MP

PRO-SERIES COMMERCIAL DRYWALL CART W/ MAX-PERFORMANCE CASTERS W/ LOCKS

3200 LB

85 LB

12

1 CART

DOA3200-MX

PRO-SERIES COMMERCIAL DRYWALL CART W/ MAX-PERFORMANCE CASTERS W/ LOCKS & BRAKES

3200 LB

86 LB

12

1 CART

DOA3200-PP

PRO-SERIES COMMERCIAL DRYWALL CART W/ MAX-ENDURANCE CASTERS W/ LOCKS

3200 LB

88 LB

12

1 CART

DOA3200-MP-PU

PRO-SERIES COMMERCIAL DRYWALL CART W/ MAX-HARD POLYURETHANE CASTERS

3200 LB

96 LB

12

1 CART

PRO SERIES

RESIDENTIAL DRYWALL CART

- 39-3/4" x 9-3/8" Nylon Skid Plate over Steel
- High quality powder coated finish
- Compatible with Max-Performance Narrow Casters only
- 2 swivel casters and 2 swivel casters with locks

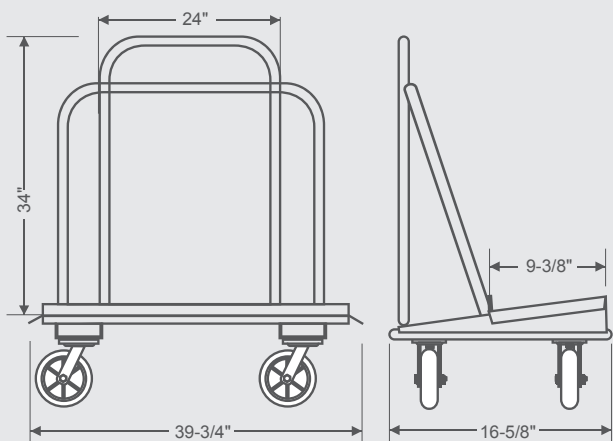

MATERIAL HANDLING

ITEM CODE	DESCRIPTION	LOAD CAPACITY	WEIGHT	PALLET/BOX COUNT	PURCHASE UNIT
DOR03	RESIDENTIAL DRYWALL CART W/ MAX-PERFORMANCE NARROW CASTERS	3200 LB	69 LB	12 PALLET	1 CART
 DOR03-P	NYLON REPLACEMENT PLATE FOR DOR03 (39-3/4" X 9-3/8" X 0.4")	N/A	3.7 LB	10 BOX	1 PLATE

FLAT CART

- 43" x 22" Steel Plate
- High quality powder coated finish
- Max-Performance Casters
- Includes 2 fixed casters, 1 swivel caster and 1 swivel caster w/ lock

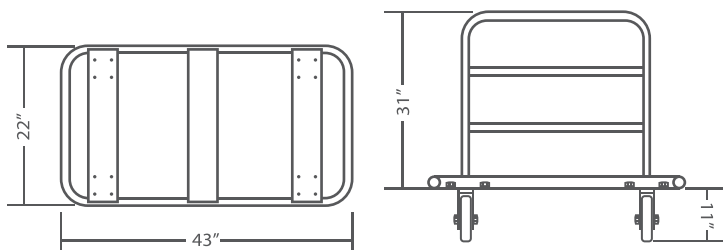

ITEM CODE	DESCRIPTION	LOAD CAPACITY	WEIGHT	PALLET COUNT	PURCHASE UNIT
CAFM2247	FLAT CART W/ MAX-PERFORMANCE CASTERS	3200 LB	68 LB	20	1 CART





DO MORE. WITH LESS.

Transform one cart into many.



Dolly

Flat Cart

Drywall Cart

Stake Cart

Introducing the **Magnum Transformer Cart**, a do-all material cart that transforms into a variety of useful haulers. No tools required. Simply grab the handles you want and go. Handles stow flat into the frame when you convert to Dolly mode. Connect two units together to form a 10' train, or connect side by side to create a 5'X4' platform. Get ready to make the most out of your cart and move some serious material. Transform the way you work, and get more done with less.



DOA4X



Handles store flat into the frame.

97° Angle

Easily relocate handles to 6 available locations. Just pull them out and position for the ideal grip.

8" Max-Endurance Casters



8" Max-Performance Casters



EASY HANDLE POSITIONING

Utilize quick-release pins to put the handles where you need them. There are six different handle mounting points.



MAX-ENDURANCE POLYURETHANE CASTERS

These hard polyurethane casters have been designed to hold up to a 5400 LB load capacity when two carts are connected and the weight is distributed evenly.

NEW MAGNUM TRANSFORMER CART

46.5" L X 27" W X 48" H
(With casters and handles)

- Easily transforms this cart into a Dolly, Flat Cart, Drywall Cart & Stake Cart, without the use of tools.
- All handles store into frame to make transport and storage easy.
- High quality steel construction w/ durable powder coated finish
- Ability to connect two carts together end-to-end, or side-by-side.
- 8" Max-Performance Casters for a premium ride and excellent maneuverability, or 8" Max-Endurance Hard Polyurethane Caster to handle the heaviest of loads.

ITEM CODE	DESCRIPTION	LOAD CAPACITY	WEIGHT	PALLET/BOX COUNT	PURCHASE UNIT
DOA4X-MP	TRANSFORMER CART W/ 8" MAX-PERFORMANCE CASTERS	3200 LB	123 LB	10 PALLET	1 CART
DOA4X-PP	TRANSFORMER CART W/ 8" MAX-ENDURANCE POLYURETHANE CASTERS	3200 LB	126 LB	10 PALLET	1 CART
 DOA4X-P	NYLON REPLACEMENT PLATE FOR DOA4X (DIMS. 46.5" X 14")	N/A	9 LB	10 BOX	1 PLATE

NEW ACCESSORY



DOA4X-A-PR

Pipe Rack Attachment for Transformer Cart



*Cart & casters sold separately

Convert your Transformer Cart into a Pipe Cart. Carry 400 LBS per rung (200 LB max. per side).



Part of our Pro Series offering, Max-Performance Casters and the Max-Endurance Casters are each designed to withstand daily punishment on the jobsite and provide increased performance and reliability. Max-Performance Casters are super smooth and easily maneuverable, whereas Max-Endurance Casters are hard Polyurethane and built to endure the heaviest of loads.

Max Casters are designed to distribute the load weight across the entire width of the hub, rather than focus the weight in the center of the hub. This principle design changes means a longer lasting caster with increased performance, reliability and durability. These non-marking casters will not pick up debris from the floor surface or fall apart prematurely like the competitors.

PRO SERIES

TAKE YOUR CASTERS TO THE

MAX

**PRO SERIES
MAX-PERFORMANCE CASTERS**

- Smoothest rolling and easiest maneuverability
- Will not collect unwanted floor debris in wheel surface
- Non-marking, and safe to all surfaces
- Holds up to maximum load capacity without warping and losing shape



DO-AB

ITEM CODE	DESCRIPTION	BOX DIMENSIONS	LOAD CAPACITY PER CASTER	BOX WEIGHT	PURCHASE UNIT
DO-AB	8" PRO SERIES MAX-PERFORMANCE CASTER KIT - 2 SWIVEL W/ LOCK, 2 SWIVEL	24.5" X 10.5" X 4.5"	800 LB	24.5 LB	1 KIT
DO-AB3	8" PRO SERIES MAX-PERFORMANCE NARROW CASTER KIT - 2 SWIVEL W/ LOCK, 2 SWIVEL	24.5" X 10.5" X 4.5"	800 LB	24.1 LB	1 KIT
DO-ABX	8" PRO SERIES MAX-PERFORMANCE CASTER KIT W/ 16 BOLTS - 2 SWIVEL W/ BRAKE & LOCK, 2 SWIVEL W/ LOCK AND 16 BOLTS	24.5" X 10.5" X 4.5"	800 LB	26 LB	1 KIT
CAFM-A	8" PRO SERIES MAX-PERFORMANCE FLAT CART CASTER KIT - 1 SWIVEL W/ LOCK, 2 FIXED, 1 SWIVEL	24.5" X 10.5" X 4.5"	800 LB	21 LB	1 KIT

**NEW PRO SERIES
MAX-ENDURANCE CASTERS**

- Hard Polyurethane for maximum durability under heavy loads
- Will not collect unwanted floor debris in wheel surface
- Non-marking, and safe to all surfaces

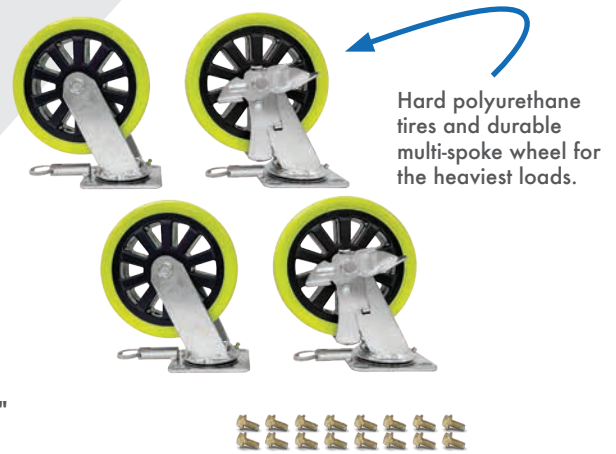

DO-APP

8" Pro Series Max-Endurance Polyurethane Caster Kit

(2 swivel w/ brake & lock, 2 swivel w/ lock, 16 bolts)

LOAD CAPACITY	900 LB PER CASTER
BOX WEIGHT	31 LB
BOX DIMENSIONS	24.5" X 10.5" X 4.5"
PURCHASE UNIT	1 KIT



**DO-A
8" Standard Non-Marking Caster Kit**

(2 swivel w/ lock, 2 swivel)

LOAD CAPACITY	800 LB PER CASTER
BOX WEIGHT	25 LB
BOX DIMENSIONS	24.5" X 10.5" X 4.5"
PURCHASE UNIT	1 KIT



**DO-APU
8" Polyurethane Caster Kit**

(2 swivel w/ lock, 2 swivel)











































LOAD CAPACITY	800 LB PER CASTER
BOX WEIGHT	36 LB
BOX DIMENSIONS	24.5" X 10.5" X 4.5"
PURCHASE UNIT	1 KIT



MATERIAL CART CASTER KIT FITMENT GUIDE

Use this guide to find the right casters for your Material Cart. Get additional caster kit details on the previous page.

WHAT FITS WHAT?

	DOA3200	DOR04	DOR03	DOA4X	CAFM2247
DO-AB 8" PRO SERIES MAX-PERFORMANCE CASTER KIT 2 swivel w/ lock, 2 swivel 	 STANDARD	 FITS	 DOES NOT FIT	 FITS	 FITS
DO-AB3 8" PRO SERIES MAX-PERFORMANCE NARROW CASTER KIT 2 swivel w/ lock, 2 swivel 	 FITS	 FITS	 STANDARD	 FITS	 FITS
DO-ABX 8" PRO SERIES MAX-PERFORMANCE CASTER KIT W/BOLTS 2 swivel w/ brake & lock, 2 swivel w/ lock, 16 bolts 	 FITS	 FITS	 DOES NOT FIT	 STANDARD ON DOA4X-MP	 FITS
CAFM-A 8" PRO SERIES MAX-PERFORMANCE FLAT CART CASTER KIT 1 swivel w/ lock, 1 swivel, 2 fixed 	 FITS	 FITS	 DOES NOT FIT	 FITS	 STANDARD
DO-A 8" STANDARD NON-MARKING CASTER KIT 2 swivel w/ lock, 2 swivel 	 FITS	 STANDARD	 DOES NOT FIT	 FITS	 FITS
DO-APU 8" POLYURETHANE CASTER KIT 2 swivel w/ lock, 2 swivel 	 FITS	 FITS	 DOES NOT FIT	 FITS	 FITS
DO-APP 8" PRO SERIES MAX-ENDURANCE CASTER KIT W/ BOLTS 2 swivel w/ brake & lock, 2 swivel w/ lock, 16 bolts 	 FITS	 FITS	 DOES NOT FIT	 STANDARD ON DOA4X-PP	 FITS



VAULT

SAFE & SECURE MOBILITY.

Secure your Service Cart. Keep your tools safe and secure by easily installing our heavy-duty Vault Security Paneling or a Vault Tool Box on our line of Service Carts.

More on Vault throughout this section of the catalog.



HEAVY-DUTY 16G STEEL WITH DURABLE POWDER COATED FINISH



KEEP YOUR TOOLS LOCKED-UP & STILL CHARGING WHEN NOT IN USE

 FITS MAGNUM, SURPRO & RUBBERMAID* CART #4520-88

 AVAILABLE IN SECURITY PANELING OR TOOL BOX VERSIONS

 KEEPS TOOLS SAFE & SECURE

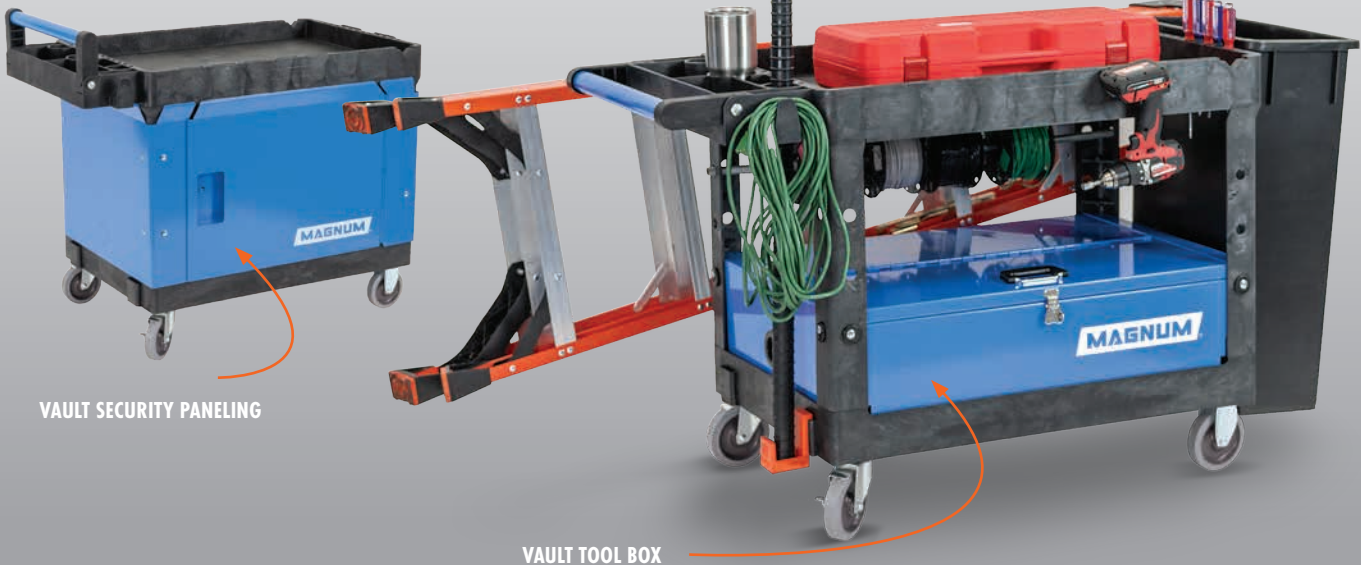

VAULT SECURITY PANELING

VAULT TOOL BOX

ITEM CODE	DESCRIPTION	ITEM WEIGHT	BOX WEIGHT	BOX DIMENSIONS	PURCHASE UNIT
CART4426-VS	VAULT SECURITY PANELING FOR 4426 PRO SERIES SERVICE CART	41 LB	49 LB	45" X 27" X 7"	1
CART4426-BS	VAULT TOOL BOX FOR 4426 PRO SERIES SERVICE CART	37 LB	43 LB	34" X 15.5" X 12"	1
CART4117-BS	VAULT TOOL BOX (SMALL) FOR ALL 4117 SERVICE CARTS	25 LB	28 LB	29" X 22" X 5"	1

*Vault Security Paneling and Vault Tool Box shown on 4426 Pro Series Cart. Vault Security Paneling not available for 4117 Service Carts. Tools, ladders, and accessories shown in photo are for illustrative purposes only. Rubbermaid is a trademark of its respective owner. Use of the trademark does not imply any affiliation with or endorsement by them.

MAGNUM

QUALITY SERVICE CARTS

All Magnum Service Carts use tough polypropylene structural foam construction and heavy-duty caster options for optimal performance on any job.

To get started, choose from our largest cart, the 4426 Pro Series with Adaptable Handle, or our smaller 4117 Series Cart with ergonomic handle.



4426 PRO SERIES
ADAPTABLE SERVICE CART

4117 PRO SERIES
ADAPTABLE SERVICE CART

4117 SERIES
ADAPTABLE SERVICE CART



NEW



NEW



44" x 25"

41" x 17"

41" x 17"

WIDE 2-SHELF SERVICE CART W/ 2-POSITION ADJUSTABLE HANDLE (STEEL HANDLE BAR - BLUE)

NARROW 2-SHELF SERVICE CART W/ 2-POSITION ADJUSTABLE HANDLE (STEEL HANDLE BAR - BLUE)

NARROW 2-SHELF SERVICE CART W/ 2-POSITION ADJUSTABLE HANDLE (PP HANDLE BAR - BLACK)

INCLUDES V-CUT IN THE TOP

INCLUDES V-CUT IN THE TOP

DOES NOT INCLUDE V-CUT IN THE TOP

INCLUDES LADDER HOOKS

INCLUDES LADDER HOOKS

DOES NOT INCLUDE LADDER HOOKS

COMPATIBLE WITH TOOL HOOK ACCESSORIES

INCLUDES (2) TOOL HOOK ACCESSORIES

COMPATIBLE WITH TOOL HOOK ACCESSORIES

MULTIPLE CASTER OPTIONS

MULTIPLE CASTER OPTIONS

PG. 21

PG. 23

PG. 23

WORKS WITH
VAULT
SECURITY PANELING & TOOL BOX



WORKS WITH
VAULT
TOOL BOX

BUILT FOR VERSATILITY

Adapt this cart for virtually any environment. Position the handle the way you want and utilize the many fastening points around the cart to hold just about anything you want. Choose from an array of 5" or 8" casters to tackle what you want. Secure your valuables and keep productivity up. The versatility is endless.



4426 PRO SERIES

ADAPTABLE SERVICE CART

44" x 25"

4426 PRO SERIES 2-Shelf Adaptable Service Carts

- Adaptable handle can be positioned flat or ergonomically to suit the user
- Two deep tray shelves to keep things in place
- Tough polypropylene structural foam construction for years of rugged dependability
- V-Cut securely holds material to assist with accurate measuring and cutting
- Mounting points for hooks, poles, tools and other handy accessories
- Easily attach Vault Security Paneling or Vault Tool Box for added safety and security



CASTER OPTIONS



5" STANDARD NON-MARKING

5" HEAVY-DUTY NON-MARKING



8" FLAT-FREE

8" PNEUMATIC/AIR



9" FLAT-FREE

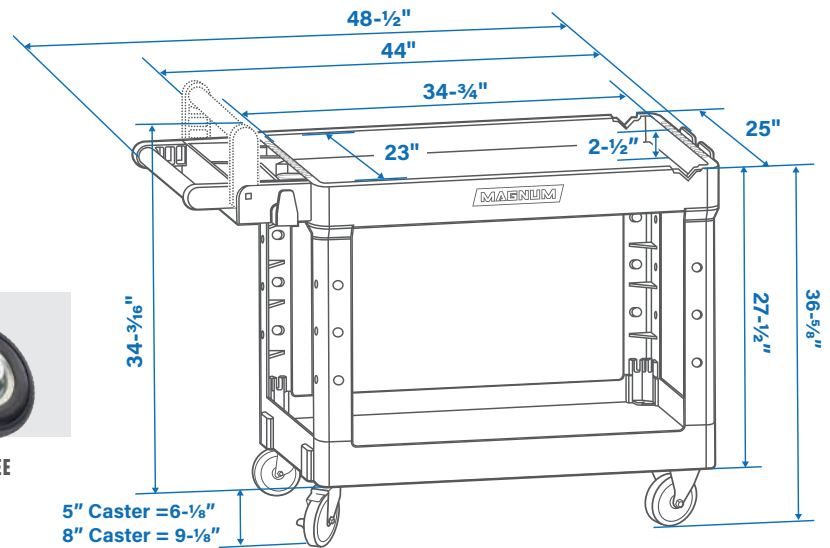

ITEM CODE

INCLUDES

LOAD CAPACITY ITEM WEIGHT BOX COUNT

CART4426-PRO-A5S	4426 PRO SERIES CART W/ 5" NON-MARKING CASTERS (2 FIXED, 2 SWIVEL)	500 LB	54 LB	1 CART
CART4426-PRO-A5H	4426 PRO SERIES CART W/ 5" HEAVY-DUTY CASTERS (2 SWIVEL, 2 SWIVEL W/BRAKE)	500 LB	57 LB	1 CART
CART4426-PRO-A8N	4426 PRO SERIES CART W/ 8" FLAT-FREE CASTERS (2 FIXED, 2 SWIVEL W/BRAKE)	500 LB	73 LB	1 CART
CART4426-PRO-A8A	4426 PRO SERIES CART W/ 8" PNEUMATIC CASTERS (2 FIXED, 2 SWIVEL W/BRAKE)	500 LB	71.2 LB	1 CART
CART4426-PRO-A9N	4426 PRO SERIES CART W/ 9" FLAT-FREE CASTERS (2 FIXED, 2 SWIVEL)	500 LB	78 LB	1 CART



BUNDLE & SAVE

PRO SERIES

ADAPTABLE SERVICE CART

+ VAULT



CART-K09

**4426 PRO SERIES CART
+ VAULT SECURITY PANELING**

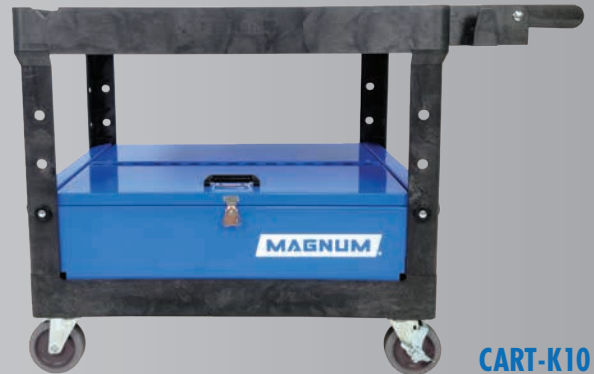

CART-K10

**4426 OR 4117 PRO SERIES CART
+ VAULT TOOL BOX**

Bundle the 4426 Pro Series Service Cart with your choice of Vault Security Paneling or Vault Tool Box, and receive a discount when purchased together as a kit. Choose from a variety of 5", 8" or 9" Caster options and tackle any obstacle. Build a narrower cart by choosing the 4117 Pro Series Service Cart with Vault Tool Box.

- Keep your assets secure
- Keep certain tools and supplies locked up safely
- Ensure that your tools are where you need them, when you need them
- Assembly required

PRO SERIES 2-Shelf Adaptable Service Carts w/ Vault Kits

ITEM CODE	DESCRIPTION	KIT WEIGHT	PURCHASE UNIT
CART-K09	4426 PRO SERIES CART W/ 5" HEAVY-DUTY CASTERS (2 SWIVEL, 2 SWIVEL W/BRAKE) + VAULT SECURITY PANELING	98 LB	1 KIT
CART-K10	4426 PRO SERIES CART W/ 5" HEAVY-DUTY CASTERS (2 SWIVEL, 2 SWIVEL W/BRAKE) + VAULT TOOL BOX	82 LB	1 KIT
CART-K11	4426 PRO SERIES CART W/ 8" FLAT-FREE CASTERS (2 FIXED, 2 SWIVEL W/BRAKE) + VAULT SECURITY PANELING	114 LB	1 KIT
CART-K12	4426 PRO SERIES CART W/ 8" FLAT-FREE CASTERS (2 FIXED, 2 SWIVEL W/BRAKE) + VAULT TOOL BOX	110 LB	1 KIT
CART-K13	4426 PRO SERIES CART W/ 8" PNEUMATIC CASTERS (2 FIXED, 2 SWIVEL W/BRAKE) + VAULT SECURITY PANELING	112 LB	1 KIT
CART-K14	4426 PRO SERIES CART W/ 8" PNEUMATIC CASTERS (2 FIXED, 2 SWIVEL W/BRAKE) + VAULT TOOL BOX	108 LB	1 KIT
CART-K18	4426 PRO SERIES CART W/ 9" FLAT-FREE CASTERS (2 FIXED, 2 SWIVEL) + VAULT SECURITY PANELING	119 LB	1 KIT
CART-K19	4426 PRO SERIES CART W/ 9" FLAT-FREE CASTERS (2 FIXED, 2 SWIVEL) + VAULT TOOL BOX	115 LB	1 KIT
CART-K05	4117 PRO SERIES CART W/ 5" HEAVY-DUTY CASTERS (2 SWIVEL, 2 SWIVEL W/BRAKE) + VAULT TOOL BOX	58 LB	1 KIT

NEW

4117 PRO SERIES

ADAPTABLE SERVICE CART

41" x 17"

4117 PRO SERIES 2-Shelf Adaptable Service Cart w/ V-Cut

- Adaptable handle can be positioned flat or ergonomically to suit the user
- Narrow width to maneuver in confined spaces
- Two deep tray shelves to keep things in place
- Tough polypropylene structural foam construction for years of rugged dependability
- V-Cut securely holds material to assist with accurate measuring and cutting
- Mounting points for hooks, poles, tools and other handy accessories (2 Free Tool Hooks included)
- Easily attach Vault Tool Box for added storage and security

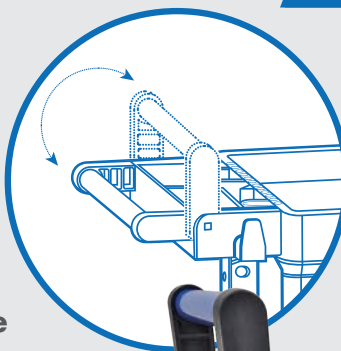

ADAPTABLE HANDLE

LADDER HOOKS

V-CUT



2 FREE TOOL HOOKS

CASTER OPTIONS



5" STANDARD



5" HEAVY-DUTY

ITEM CODE	DESCRIPTION	INCLUDES VAULT:	LOAD CAPACITY	ITEM WEIGHT	PURCHASE UNIT
CART4117-PRO-A5S	4117 CART W/ 5" NON-MARKING CASTERS (2 FIXED, 2 SWIVEL)	NO	500 LB	29.8 LB	1 CART
CART4117-PRO-A5H	4117 CART W/ 5" HEAVY-DUTY CASTERS (2 SWIVEL, 2 SWIVEL W/BRAKE)	NO	500 LB	32.3 LB	1 CART
CART-K05	4117 CART W/ 5" HEAVY-DUTY CASTERS (2 SWIVEL, 2 SWIVEL W/BRAKE)	VAULT TOOL BOX	500 LB	58 LB	1 KIT

NEW

4117 UTILITY

ADAPTABLE SERVICE CART

41" x 17"

4117 Utility 2-Shelf Adaptable Service Cart

- Adaptable handle can be positioned flat or ergonomically to suit the user
- Narrow width to maneuver in confined spaces
- Two deep tray shelves to keep things in place
- Tough polypropylene structural foam construction for years of rugged dependability
- Easily attach Vault Tool Box for added storage and security

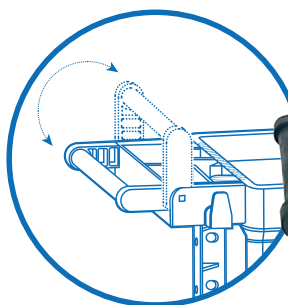

5" STANDARD NON-MARKING CASTERS

ITEM CODE	DESCRIPTION	INCLUDES VAULT:	LOAD CAPACITY	ITEM WEIGHT	PURCHASE UNIT
CART4117-UTY-A5S	4117 CART W/ 5" NON-MARKING CASTERS (2 FIXED, 2 SWIVEL)	NO	500 LB	28.1 LB	1 CART





5" Standard Non-Marking Casters

Standard non-marking casters.

ITEM CODE	DESCRIPTION	CASTER SIZE	WEIGHT	PURCHASE UNIT
CASU5-F	STANDARD CASTERS - FIXED	5" X 1"	0.9 LB	1 CASTER
CASU5-S	STANDARD CASTERS - SWIVEL	5" X 1"	1.1 LB	1 CASTER
CARTA-A5S	STANDARD CASTER KIT - 2 STANDARD FIXED, 2 STANDARD SWIVEL AND SCREW HARDWARE	5" X 1"	5 LB	1 SET



5" Heavy-Duty Non-Marking Casters

Heavy-duty, non-marking casters.

ITEM CODE	DESCRIPTION	CASTER SIZE	WEIGHT	PURCHASE UNIT
CASU5-F-HD	HEAVY-DUTY CASTERS - FIXED	5" X 1-1/4"	1.43 LB	1 CASTER
CASU5-BR-HD	HEAVY-DUTY CASTERS - SWIVEL W/ BRAKE	5" X 1-1/4"	2.09 LB	1 CASTER
CARTA-A5H	HEAVY-DUTY CASTER KIT - 2 FIXED, 2 SWIVEL W/ BRAKE AND SCREW HARDWARE	5" X 1-1/4"	7.92 LB	1 SET

8" Heavy-Duty Flat-Free Casters

Fits service carts. Flat-free casters large enough to roll over obstacles easier, and provide added floor protection. 3" X 3" bolt pattern on plate.



ITEM CODE	DESCRIPTION	CASTER SIZE	WEIGHT	PURCHASE UNIT
CASU8N-F	FLAT-FREE CASTER - FIXED	8" X 2"	4 LB	1 CASTER
CASU8N-BR	FLAT-FREE CASTER - SWIVEL W/ BRAKE	8" X 2"	6 LB	1 CASTER
CARTA-A8N	FLAT-FREE CASTER SET - 2 FIXED, 2 SWIVEL W/ BRAKE AND SCREW HARDWARE	8" X 2"	22 LB	1 SET

8" Heavy-Duty Pneumatic/Air Casters

Fits service carts. Pneumatic/air casters provide better traction and a smoother ride. The shock-absorbing ride helps protect valuable cargo. 3" X 3" bolt pattern on plate.



ITEM CODE	DESCRIPTION	CASTER SIZE	WEIGHT	PURCHASE UNIT
CASU8A-F	PNEUMATIC/AIR CASTER - FIXED	8" X 2"	3.5 LB	1 CASTER
CASU8A-BR	PNEUMATIC/AIR CASTER - SWIVEL W/ BRAKE	8" X 2"	5.3 LB	1 CASTER
CARTA-A8A	PNEUMATIC/AIR CASTER SET - 2 FIXED, SWIVEL W/ BRAKE AND SCREW HARDWARE	8" X 2"	20.2	1 SET



9" Heavy-Duty Flat-Free Casters

Fits service carts. Flat-free casters large enough to roll over obstacles easier, and provide added floor protection.

ITEM CODE	DESCRIPTION	CASTER SIZE	WEIGHT	PURCHASE UNIT
CAS9-NF-WF-N	CASTERS - FIXED	9" X 3"	6 LB	1 CASTER
CAS9-NF-WS-N	CASTERS - SWIVEL	9" X 3"	7 LB	1 CASTER
CARTA-A9N	CASTER KIT - 2 FIXED, 2 SWIVEL	9" X 3"	26 LB	1 SET

SERVICE CART ACCESSORIES

Want to hook your service cart up with handy accessories? Just clip on these and go! Super convenient for transporting poles, tools, ladders, and cords.



TIR10H
EPDM TIE DOWNS

Keep your ladder secure on our built in cart hooks, or Tool Hook accessories. Not sold individually. Included in our Service Ladder Kits below (CARTA-L & CARTA-TPL).



CARTA-22H
Tool Hook w/ Hole

Attach to the top or bottom shelf. Use as a hook, as well as, a pole tool holder when used in conjunction with CARTA-22 as a pole tool base.



CARTA-22
Tool Hook

Attach to the top or bottom shelf. Use as a hook and most commonly as a pole tool base when used in conjunction with CARTA-22H.



OUT3USB
Power Strip

3-Outlet Power Strip with 2 USB Ports and 9' Cord.

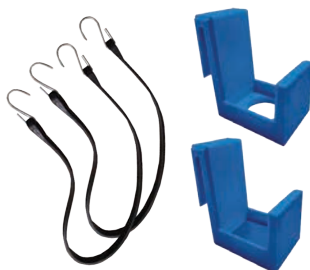

CARTA-L
Service Cart Ladder Hook Kit

Includes:
(2) EPDM Tie Downs
(1) Tool Hook w/ Hole
(1) Tool Hook

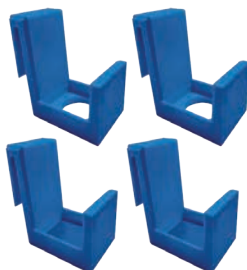

CARTA-TP
Service Cart Tool & Pole Hook Kit

Includes:
(2) Tool Hooks w/ Hole
(2) Tool Hooks

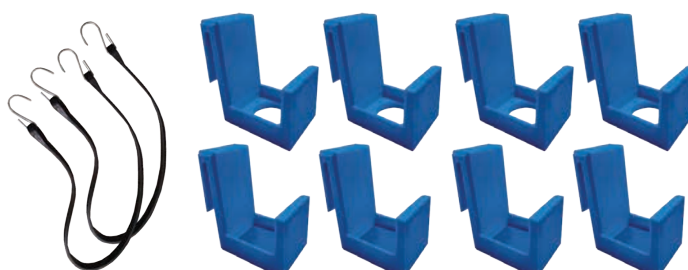

CARTA-TPL
Service Cart Ladder, Tool & Pole Hook Kit

Includes:
(2) EPDM Tie Downs
(4) Tool Hooks w/ Hole
(4) Tool Hooks



6 CU. FT. STEEL DUAL WHEEL WHEELBARROWS

- 6 cubic feet capacity
- Dual wheels offer better balance
- Heavy-duty 12 gauge steel tray
- Reinforced tray braces
- 16" Pneumatic or Flat-free tires
- Steel or wood handles

DUAL WHEELS

offer better balance when carrying heavier loads.



Flat-Free

Pneumatic

ITEM CODE	DESCRIPTION	WHEEL/TIRE SIZE	LOAD CAPACITY	ITEM WEIGHT	PURCHASE UNIT
BAWH6-SHA-2	6 CU. FT. STEEL WHEELBARROW W/ DUAL PNEUMATIC TIRES (STEEL HANDLE)	16"	6 CU. FT.	55 LB	1
BAWH6-SHF-2	6 CU. FT. STEEL WHEELBARROW W/ DUAL FLAT-FREE TIRES (STEEL HANDLE)	16"	6 CU. FT.	59 LB	1
BAWH6-WHA-2	6 CU. FT. STEEL WHEELBARROW W/ DUAL PNEUMATIC TIRES (WOOD HANDLE)	16"	6 CU. FT.	53 LB	1
BAWH6-WHF-2	6 CU. FT. STEEL WHEELBARROW W/ DUAL FLAT-FREE TIRES (WOOD HANDLE)	16"	6 CU. FT.	57 LB	1

6 CU. FT STEEL WHEELBARROWS

- 6 cubic feet capacity
- Heavy-duty 12 gauge steel tray
- Reinforced tray braces
- 16" Pneumatic or Flat-free tires
- Steel or wood handles

SINGLE WHEEL

offers better maneuverability when cornering.



Flat-Free

WOOD

ITEM CODE	DESCRIPTION	WHEEL/TIRE SIZE	LOAD CAPACITY	ITEM WEIGHT	PURCHASE UNIT
BAWH6-SHA	6 CU. FT. STEEL WHEELBARROW W/ PNEUMATIC TIRE (STEEL HANDLE)	16"	6 CU. FT.	49 LB	1
BAWH6-SHF	6 CU. FT. STEEL WHEELBARROW W/ FLAT-FREE TIRE (STEEL HANDLE)	16"	6 CU. FT.	50 LB	1
BAWH6-WHA	6 CU. FT. STEEL WHEELBARROW W/ PNEUMATIC TIRE (WOOD HANDLE)	16"	6 CU. FT.	46 LB	1
BAWH6-WHF	6 CU. FT. STEEL WHEELBARROW W/ FLAT-FREE TIRE (WOOD HANDLE)	16"	6 CU. FT.	47 LB	1

Pneumatic



DUAL WHEEL WHEELBARROW CONVERSION KITS

Convert a single wheel wheelbarrow into a dual wheel wheelbarrow. Kit assumes that you already have one wheel.

- (1) Wheel - Choose Pneumatic or Flat-Free
- (2) Axle Brackets
- (2) Hair Pins
- (4) Washers
- (1) Long Axle



ITEM CODE	DESCRIPTION	DIAMETER	WIDTH	WEIGHT	BOX COUNT	PURCHASE UNIT
BAWH6-2A	DUAL PNEUMATIC TIRE CONVERSION KIT - 1 PNEUMATIC TIRE/WHEEL, 2 AXLE BRACKETS, 2 HAIR PINS, 4 WASHERS, 1 LONG AXLE	16"	4"	5.3 LB	4	1 TIRE
BAWH6-2F	DUAL FLAT-FREE TIRE CONVERSION KIT - 1 FLAT-FREE TIRE/WHEEL, 2 AXLE BRACKETS, 2 HAIR PINS, 4 WASHERS, 1 LONG AXLE	16"	4"	6.4 LB	4	1 TIRE



WHEELBARROW TIRE/WHEEL

ITEM CODE	DESCRIPTION	DIAMETER	WIDTH	WEIGHT	BOX COUNT	PURCHASE UNIT
TIAK16-BB	PNEUMATIC TIRE/WHEEL (STEEL - BLACK)	16"	4"	5.3 LB	4	1 TIRE
TINK16-BC	FLAT-FREE TIRE/WHEEL (6-SPOKE METAL HUB)	16"	4"	6.4 LB	4	1 TIRE

*Tires/Wheels fit both Dual Wheelbarrows and Single Wheelbarrows.



WHEELBARROW REPLACEMENT HANDLES

ITEM CODE	DESCRIPTION	SIZE	WEIGHT	PURCHASE UNIT
HDWB	WHEELBARROW HANDLE, WOOD	59" X 1-1/2" X 1-3/4"	3.2 LB	1 PIECE
BAWH6-P3	WHEELBARROW HANDLE, STEEL	59" X 1-1/2" X 1-1/2"	4.4 LB	1 PIECE



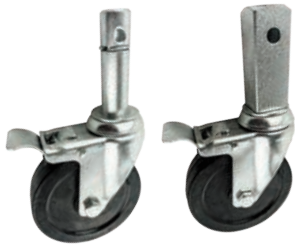

ROUND GRIP STEM & SQUARE STEM CASTERS

6' Scaffold replacement casters

ITEM CODE	CASTER TYPE	WHEEL DIAMETER	WHEEL WIDTH	ITEM WEIGHT	BOX COUNT	PURCHASE UNIT
CAS5RL	ROUND STEM - SWIVEL W/ LOCK	5"	2"	3.5 LB	10	1 CASTER
CAS5SL	SQUARE STEM - SWIVEL W/ LOCK	5"	2"	4.4 LB	10	1 CASTER



THREADED STEM CASTERS

ITEM CODE	CASTER TYPE	CASTER DIAMETER	CASTER WIDTH	ITEM WEIGHT	BOX COUNT	PURCHASE UNIT
CAS3W	SWIVEL	3"	2"	1.43 LB	30	1 CASTER
CAS4W	SWIVEL	4"	2"	2 LB	20	1 CASTER



POLYPROPYLENE PLATE CASTERS

ITEM CODE	CASTER TYPE	CASTER DIAMETER	CASTER WIDTH	ITEM WEIGHT	BOX COUNT	PURCHASE UNIT
CAS4PF	FIXED	4"	2"	3.37 LB	20	1 CASTER
CAS4PS	SWIVEL	4"	2"	4.12 LB	20	1 CASTER
CAS4PS-NM	SWIVEL / NON-MARKING	4"	2"	4.6 LB	10	1 CASTER
CAS5PF	FIXED	5"	2"	3.8 LB	10	1 CASTER
CAS5PS	SWIVEL	5"	2"	4.6 LB	10	1 CASTER
CAS5PS-NM	SWIVEL / NON-MARKING	5"	2"	4.6 LB	10	1 CASTER
CAS6PF	FIXED	6"	2"	4.2 LB	10	1 CASTER
CAS6PS	SWIVEL	6"	2"	4.9 LB	10	1 CASTER



JOB BOX CASTER SETS

Set of four (4) Polypropylene casters. Fits Greenlee, Knaack and other manufacturers.



ITEM CODE	CASTER TYPE	CASTER DIAMETER	CASTER WIDTH	ITEM WEIGHT	BOX COUNT	PURCHASE UNIT
CAS4-K	4" CASTER SET - 2 SWIVEL/2 FIXED	4"	2"	16 LB	4	1 SET
CAS5-K	5" CASTER SET - 2 SWIVEL/2 FIXED	5"	2"	20 LB	4	1 SET
CAS6-K	6" CASTER SET - 2 SWIVEL/2 FIXED	6"	2"	24 LB	4	1 SET

PNEUMATIC (AIR) & FLAT-FREE CASTERS

Fits service carts. 8" x 2" casters. Available in Pneumatic (Air) and Flat-Free style.



ITEM CODE	CASTER TYPE	CASTER DIAMETER	CASTER WIDTH	ITEM WEIGHT	BOX COUNT	PURCHASE UNIT
CASU8A-BR	PNEUMATIC SWIVEL W/ BRAKE	8"	2"	5.3 LB	4	1 CASTER
CASU8A-F	PNEUMATIC FIXED	8"	2"	3.5 LB	4	1 CASTER
CASU8N-BR	FLAT-FREE SWIVEL W/ BRAKE	8"	2"	6 LB	4	1 CASTER
CASU8N-F	FLAT-FREE FIXED	8"	2"	4 LB	4	1 CASTER





9" CASTERS

Fits service carts. 9" x 3" Flat-Free casters.

ITEM CODE	CASTER TYPE	CASTER DIAMETER	CASTER WIDTH	ITEM WEIGHT	BOX COUNT	PURCHASE UNIT
CAS9-NF-WF-N	FIXED	9"	3"	6 LB	4	1 CASTER
CAS9-NF-WS-N	SWIVEL	9"	3"	7 LB	4	1 CASTER

See Fitment Guide on PG.17

PRO SERIES MAX-PERFORMANCE CASTERS

Our top-of-the-line Material Cart Casters built for easy maneuverability and longevity.



ITEM CODE	CASTER TYPE	CASTER DIAMETER	CASTER WIDTH	ITEM WEIGHT	BOX COUNT	PURCHASE UNIT
CAS800F-B	FIXED	8"	2"	4 LB	4	1 CASTER
CAS800S-B	SWIVEL	8"	2"	6 LB	4	1 CASTER
CAS800L-B	SWIVEL W/ LOCK	8"	2"	6.5 LB	4	1 CASTER
CAS800S-B3*	SWIVEL (NARROW PLATE)	8"	2"	3.7 LB	4	1 CASTER
CAS800L-B3*	SWIVEL W/ LOCK (NARROW PLATE)	8"	2"	5.7 LB	4	1 CASTER

*Narrow Plate Casters (XXXXXX-B3) are required on Residential Drywall Cart DOR03, and will also fit all other Material Carts.



PRO SERIES MAX-ENDURANCE CASTERS

Our top-of-the-line Polyurethane Material Cart Casters built for maximum durability.

ITEM CODE	CASTER TYPE	CASTER DIAMETER	CASTER WIDTH	ITEM WEIGHT	BOX COUNT	PURCHASE UNIT
CAS8PP-SLB	SWIVEL W/ LOCK & BRAKE	8"	2"	7 LB	4	1 CASTER
CAS8PP-SL	SWIVEL W/ LOCK	8"	2"	6 LB	4	1 CASTER



NON-MARKING CASTERS

Fits all Material Carts, except Residential Drywall Cart DOR03.

ITEM CODE	CASTER TYPE	CASTER DIAMETER	CASTER WIDTH	ITEM WEIGHT	BOX COUNT	PURCHASE UNIT
CAS800F-Y	FIXED	8"	2"	4 LB	4	1 CASTER
CAS800S-Y	SWIVEL	8"	2"	6 LB	4	1 CASTER
CAS800B-Y	SWIVEL W/ LOCK	8"	2"	6.5 LB	4	1 CASTER



STANDARD POLYURETHANE CASTERS

Fits all Material Carts, except Residential Drywall Cart DOR03.

ITEM CODE	CASTER TYPE	CASTER DIAMETER	CASTER WIDTH	ITEM WEIGHT	BOX COUNT	PURCHASE UNIT
CAS8FPU	FIXED W/ LOCK	8"	2"	8 LB	4	1 CASTER
CAS8SPU	SWIVEL	8"	2"	9 LB	4	1 CASTER
CAS8BPU	SWIVEL W/ LOCK	8"	2"	9 LB	4	1 CASTER



SAFE-ST

ITEM CODE

FIREBOX™

34" PORTABLE FIRE EXTINGUISHER STAND & SAFETY STATION

Stay in compliance and keep your jobsites and people safe with the Magnum Firebox- a flat-pack portable fire extinguisher stand that also serves as a safety station.

- Holds up to 30 LB Extinguisher
- Lightweight, sturdy and durable polypropylene construction for years of reliable use
- Flat-pack design for cost-effective shipping/transport and easy assembly/disassembly and storage
- EZ-Grip hand holds on all sides allows for one person to carry two units

ITEM CODE	ITEM WEIGHT	SHIPPING WEIGHT	SHIPPING DIMENSIONS	PALLET COUNT	PURCHASE UNIT
SAFE-ST	13 LB	16 LB	36"X21"X7"	32	1



MOUNT SAFETY ACCESSORIES ON ALL FOUR SIDES



Ready for screw mounting First Aid Kit, Eye Wash Station, Dust Masks and other safety supplies

OSHA COMPLIANT

1926.150 (A)(1,2,3,4) & (C)(1)(I),
1926.24, 1910.144 & 1910.157(C)

Patent Pending.



MAGNUM™

WORK PLATFORMS



ALUMINUM STEP-UP BENCHES

- Extra Heavy-Duty Type 1A
- Bench top load capacity: **300 LB**
- Durable aluminum construction
- Extra-wide 10" split top
- Available in 2, 2.5, 3 & 4 ft
- Hex cap (partially threaded) bolts reduce joint wear and increase longevity of the product
- Double-rivets reinforce each step to provide added safety and security

Meets all OSHA requirements.

HEAVY-DUTY ALUMINUM

EXTRA WIDE 10" TOP



Safe and sturdy. Lightweight, yet rugged aluminum construction. Magnum Step-Up Benches are versatile step ladders, portable work platforms, sawhorses and benches, all-in-one. They fold up quickly for storage and transport. Used as a pair, they are a great solution for two-person jobs or for creating a large working surface.



ALUMINUM

STS2

STS212-3

STS3

STS4

	STS2	STS212-3	STS3	STS4
HEIGHT	2'	2.5'	3'	4'
LOAD CAPACITY	300 LB	300 LB	300 LB	300 LB
ITEM WEIGHT	12 LB	18.4 LB	20.5 LB	26 LB
PALLET COUNT	10 BENCHES	10 BENCHES	10 BENCHES	10 BENCHES
PURCHASE UNIT	1 BENCH	1 BENCH	1 BENCH	1 BENCH

MAGNUM

MAGNUM

FIBERGLASS STEP-UP BENCHES

- Extra Heavy-Duty Type 1A
- Bench top load capacity: **300 LB**
- Non-conductive fiberglass legs
- Extra-wide 10" split top
- Available in 2, 2.5, 3 & 4 ft
- Double-rivets reinforce each step to provide added safety and security

Meets all OSHA requirements.

NON-CONDUCTIVE FIBERGLASS

EXTRA WIDE 10" TOP



Durable steel leg braces wrap around the bench top for added strength.



Reinforced fully-enclosed crossbeams add durability and increased stability.



No-slip, no-mark rubber feet with durable base frames.

Safe and sturdy. Non-conductive fiberglass legs and rugged aluminum construction. Steel top leg braces. Magnum Step-Up Benches are versatile step ladders, portable work platforms, sawhorses and benches, all-in-one. They fold up quickly for storage and transport. Used as a pair, they are a great solution for creating a large working surface.



FIBERGLASS

STS2-F

STS212-F3

STS3-F

STS4-F

HEIGHT	2'	2.5'	3'	4'
LOAD CAPACITY	300 LB	300 LB	300 LB	300 LB
ITEM WEIGHT	16.7 LB	22 LB	23.2 LB	29.7 LB
PALLET COUNT	10 BENCHES	10 BENCHES	10 BENCHES	10 BENCHES
PURCHASE UNIT	1 BENCH	1 BENCH	1 BENCH	1 BENCH

WORK PLATFORMS



6' PORTABLE BAKER SCAFFOLD

SCF6B

- Dimensions: 73.5" L x 29" W x 75" H
- 1/2" Plywood Deck with Steel Frame
- 5" Swivel Casters with Brake
- Fits through Standard Doorways
- High-Quality Powder Coated Finish
- Compatible with other Baker Scaffold



CONVENIENT, SECURE, SPRING LOADED PLATFORM LOCK



SPRING LOADED D-HANDLE LOCKS FOR SAFE AND EASY HEIGHT ADJUSTMENT



HIGH QUALITY SPRING CLIPS & LOCKING PINS FOR ADDED SECURITY

Easy Stacking!

STACK TWO UNITS UP TO 12FT



1000 LB LOAD CAPACITY

OSHA
29 CFR Pt. 1926

ANSI
A10.8

CSA
S269.2 M87

ITEM CODE	DESCRIPTION	ITEM WEIGHT	ITEM DIMENSIONS	BOX DIMENSIONS	PALLET COUNT	PURCHASE UNIT
SCF6B	6' BAKER SCAFFOLD W/ STANDARD WALKBOARD	119 LB	73.5" X 29" X 75"	75" X 30" X 5.3"	12 UNITS	1 UNIT

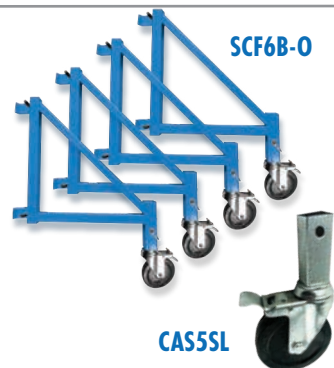

PARTS & ACCESSORIES *

Quality replacement parts and accessories for 6' Baker Style Scaffold.

*Color of available accessories may vary.



ITEM CODE	DESCRIPTION	ITEM WEIGHT	BOX COUNT	PURCHASE UNIT
SCF6B-O	14" OUTRIGGERS	33 LB	4	1 PACK
CAS5SL	5" SWIVEL CASTER W/ BRAKE	4.4 LB	10	1 CASTER
SCF6B-G	GUARDRAIL SET	55 LB	1	1 SET
SCF6B-B	PLATFORM BRACES	16.5 LB	2	1 BRACE
SCF6B-F	SIDE FRAMES	17.6 LB	2	1 FRAME
SCF6B-H	WALKBOARD W/ ACCESS HATCH	33 LB	1	1 WALKBOARD
SCF6B-W	WALKBOARD, STANDARD	33 LB	1	1 WALKBOARD
SCF6B-P	LOCKING PIN	0.12 LB	40	1 PIN

MAGNUM

TM



WE'VE GOT YOU COVERED.

Rest assured that your purchase of Magnum Material Handling products is safe with the included one-year limited warranty. The Magnum Tool Corp., Inc. warranty protects against manufacturing defects from the date of purchase for an entire year. See warranty card for details and restrictions.

COAST-TO-COAST SUPPORT.

Magnum has dealers across the United States, Canada and abroad. Contact us to find a dealer near you. Don't hesitate to reach out with any questions you may have. We'll do our best to help.





Magnum Tool Corp., Inc.
5600 Bonhomme Rd, Suite B
Houston, TX 77036

1 (888) 443-8889 fax (713) 781-5677

sales@magnum-tool.com

www.magnum-tool.com