

MAGNUM

TM



**MATERIAL HANDLING
& WORK PLATFORMS**

CATALOG VERSION 24.9

TM

MAGNUM

SINCE 1989

In 1989, Magnum Tool Corp, Inc. began its journey as a tool distributor in our hometown of Houston, Texas. Aiming to build a lasting imprint on our community, we focused on establishing a reputation for delivering professional-grade tools and equipment at exceptional value. We are blessed and proud of the company we've built with the support of our community, our great team, the network of distribution we have cultivated, and the many loyal contractors that use our tools and equipment worldwide.

Today, Magnum offers a great selection of Material Handling Equipment, Drywall Specific Tools and Material, Step-Up Benches, Fasteners, and more. We continue to innovate and add value to the products we develop and carry. Magnum products are engineered to excel with rugged daily use. Whether it's a dump cart tub that tilts easily, maneuvers through narrow passages, and still transports efficiently, or the latest in drywall cart design; Magnum provides professional-grade equipment to keep you moving.

Our product line encompasses a wide offering to support residential, commercial, industrial, and general construction. Tradespeople, such as acoustical contractors, electricians, drywall contractors, janitors, and facilities workers are at the core of our loyal user base. Our commitment to excel through friendly and knowledgeable customer service, product training, and support, is what sets Magnum apart. Our devoted team works in tandem to ensure your satisfaction.

Welcome to the family!

VISIT MAGNUM-TOOL.COM





MATERIAL HANDLING



<i>DUMP CARTS & ACCESSORIES</i>	6-9
<i>TRASH CANS & ACCESSORIES</i>	10-11
<i>MATERIAL CARTS & ACCESSORIES</i>	12-17
<i>UTILITY/SERVICE CARTS, VAULT & DRAFTDECK</i>	18-25
<i>WHEELBARROWS, PARTS & ACCESSORIES</i>	26-27
<i>CASTERS & TIRES</i>	28-29
FIREBOX™	30



WORK PLATFORMS

<i>STEP-UP BENCHES</i>	31-33
<i>SCAFFOLD & ACCESSORIES</i>	34



**JOBSITE
READY**

MATERIAL HANDLING

Our products are designed to work as hard as you. They carry their weight and perform on the daily. Moving material, moving your job forward, and making it happen.





DUMP CARTS



MATERIAL CARTS



SERVICE CARTS



MATERIAL HANDLING



MAGNUM™

Save freight and space by stacking more on a pallet.

- Premium injection molded tubs for added strength in corners
- Smooth surface is easy to clean and resists corrosion
- Fits through standard doorways and elevators
- Handling can be performed by a single user
- Construction grade wheels and casters

1/2 Cubic Yard Dump Cart



750 LB LOAD CAPACITY

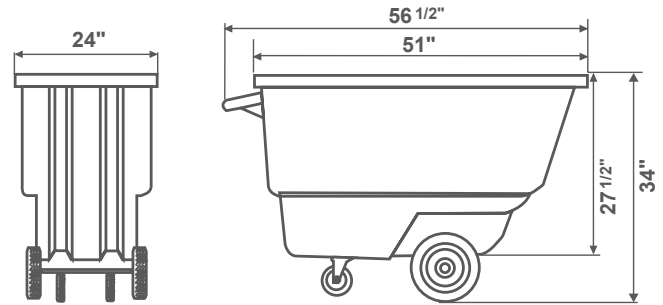

ITEM CODE	CASTER TYPE	WHEEL TYPE	ITEM WEIGHT	PALLET COUNT
DUC12T	4" HEAVY-DUTY	10" HEAVY-DUTY	64 LB	14
DUC12T-NM*	5" NON-MARKING	12" NON-MARKING	48 LB	14

*Use 2-5/8" Axle (DUA12-575)

1 Cubic Yard Covered Capacity Dump Cart



800 LB LOAD CAPACITY

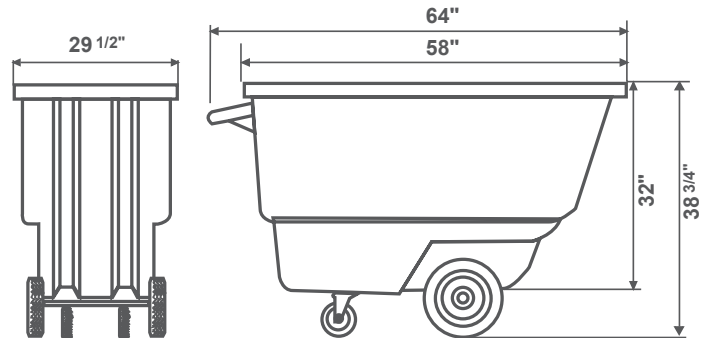

ITEM CODE	CASTER TYPE	WHEEL TYPE	ITEM WEIGHT	PALLET COUNT
DUC100-12	5" HEAVY-DUTY	12" HEAVY-DUTY	89 LB	12
DUC100-12-NM	5" NON-MARKING	12" NON-MARKING	73 LB	12



**1 Cubic Yard Covered Capacity Dump Cart w/
Reinforcing Frame**

UP TO 1000 LB LOAD CAPACITY

ITEM CODE	CASTER TYPE	WHEEL TYPE	LOAD CAPACITY	ITEM WEIGHT	PALLET COUNT
DUC100-R	5" HEAVY-DUTY	12" HEAVY-DUTY	1000 LB	94 LB	12
DUC100-R-NM	5" NON-MARKING	12" NON-MARKING	900 LB	78 LB	12



**1 Cubic Yard Covered Capacity Dump Cart w/
Heavy-Duty Full Frame**

UP TO 1200 LB LOAD CAPACITY

ITEM CODE	CASTER TYPE	WHEEL TYPE	LOAD CAPACITY	ITEM WEIGHT	PALLET COUNT
DUC100-H	5" HEAVY-DUTY	12" HEAVY-DUTY	1200 LB	112 LB	10
DUC100-H-NM	5" NON-MARKING	12" NON-MARKING	950 LB	96 LB	10



**UP TO
1250 LB LOAD CAPACITY**

Same sizes as our other Dump Carts yet compatible with forklifts and automated lifters due to the heavy-duty forklift ready frame.



**MAGNUM HEAVY-DUTY
FORKLIFT READY DUMP CARTS**

ITEM CODE	DESCRIPTION	LOAD CAPACITY	CASTER TYPE	WHEEL TYPE	ITEM WEIGHT	PALLET COUNT
DUC12T-F	1/2 CU. YD. FORK LIFT READY DUMP CART, HD	850 LB	5" HEAVY-DUTY	12" HEAVY-DUTY	79 LB	8
DUC12T-F-NM	1/2 CU. YD. FORK LIFT READY DUMP CART, NM	850 LB	5" NON-MARKING	12" NON-MARKING	63 LB	8
DUC100-F	1 CU. YD. COVERED CAPACITY FORKLIFT READY DUMP CART, HD	1250 LB	5" HEAVY-DUTY	12" HEAVY-DUTY	103 LB	7
DUC100-F-NM	1 CU. YD. COVERED CAPACITY FORKLIFT READY DUMP CART, NM	1000 LB	5" NON-MARKING	12" NON-MARKING	87 LB	7



DUMP CART FRAMES

MATERIAL HANDLING

Premium steel powder coated frames resist corrosion.

DUF100R

Reinforcing Frame for 1 Cubic Yard Covered Capacity Dump Cart

Add to any existing 1 CU. YD. Covered Capacity Dump Cart. No additional hardware needed.



ITEM WEIGHT
5 LB

PURCHASE UNIT
1 FRAME

DUF100H

Heavy Duty Frame for 1 Cubic Yard Covered Capacity Dump Cart

Add to any existing 1 CU. YD. Covered Capacity Dump Cart. No additional hardware needed.



ITEM WEIGHT
23 LB

PURCHASE UNIT
1 FRAME

DUF12F-K

Forklift Ready Frame Kit for 1/2 Cubic Yard Dump Cart

Includes: (1) Forklift Ready Frame, (2) Heavy-Duty 5" Casters, (2) Heavy-Duty 12" Wheels and (1) DUA12-575 Axle.



ITEM WEIGHT
18 LB

PURCHASE UNIT
1 FRAME

DUF100F

Forklift Ready Frame for 1 Cubic Yard Covered Capacity Dump Cart

Add to any existing 1 CU. YD. Covered Capacity Dump Cart. No additional hardware needed.



ITEM WEIGHT
21 LB

PURCHASE UNIT
1 FRAME

DUMP CART LIDS & ACCESSORIES

DUMP CART FABRIC LIDS



DUL12T-F

Soft Fabric Lid for Magnum 1/2 Cubic Yard Dump Cart

DIMENSIONS 51" X 29" X 6.75"
ITEM WEIGHT 3.50 LB

DUL-F

Universal Soft Fabric Lid for 1 Cubic Yard Covered Capacity Dump Cart

DIMENSIONS 67" X 29" X 6.75"
ITEM WEIGHT 3.75 LB

DUL100-F

Soft Fabric Lid for Magnum 1 Cubic Yard Covered Capacity Dump Cart

DIMENSIONS 55" X 29" X 6.75"
ITEM WEIGHT 3.70 LB



DUMP CART PLASTIC LIDS

Plastic Lid for 1/2 Cubic Yard Dump Cart

DUL12T

ITEM WEIGHT	12 LB
PURCHASE UNIT	1 LID

Plastic Lid for 1 Cubic Yard Covered Capacity Dump Cart

DUL100

ITEM WEIGHT	17 LB
PURCHASE UNIT	1 LID

DUMP CART AXLES



ITEM CODE	WORKS WITH	AXLE LENGTH	WEIGHT	BOX COUNT	PURCHASE UNIT
DUA12-550	1/2 CU. YD. CART	21-5/8"	3 LB	1	1 AXLE
DUA12-575*	1/2 CU. YD. CART	22-5/8"	3.3 LB	1	1 AXLE
DUA100-12	1 CU. YD. COVERED CAPACITY CART	24-3/8"	4 LB	1	1 AXLE

*Use this axle on 1/2 cubic yard dump carts (DUC12T-NM and DUC12T-F) when using 5" non-marking casters (CAS5PS-NM) & 12" non-marking wheels (CAS12-NM).

DUMP CART PLATE CASTERS



ITEM CODE	CASTER TYPE	WHEEL DIAMETER	WHEEL WIDTH	WEIGHT	BOX COUNT	PURCHASE UNIT
CAS4PS	HEAVY-DUTY	4"	2"	4 LB	20	1 CASTER
CAS5PS	HEAVY-DUTY	5"	2"	4.6 LB	10	1 CASTER
CAS5PS-NM	NON-MARKING	5"	2"	4.2 LB	10	1 CASTER

DUMP CART WHEELS



ITEM CODE	WHEEL TYPE	WHEEL DIAMETER	WHEEL WIDTH	WEIGHT	BOX COUNT	PURCHASE UNIT
CAS10	HEAVY-DUTY	10"	2-3/4"	7 LB	2	1 WHEEL
CAS12	HEAVY-DUTY	12"	3"	11 LB	2	1 WHEEL
CAS12-NM	NON-MARKING	12"	3"	3 LB	2	1 WHEEL



UNFAILING

MAGNUM

PRO SERIES TRASH CANS

Expect excellent quality, innovative features, and superior functionality without sacrificing durability and value. Welcome to **Magnum Pro Series** - professional grade equipment that works hard and stands up to daily work site punishment.



GRAY

YELLOW

RED

FEATURES & BENEFITS

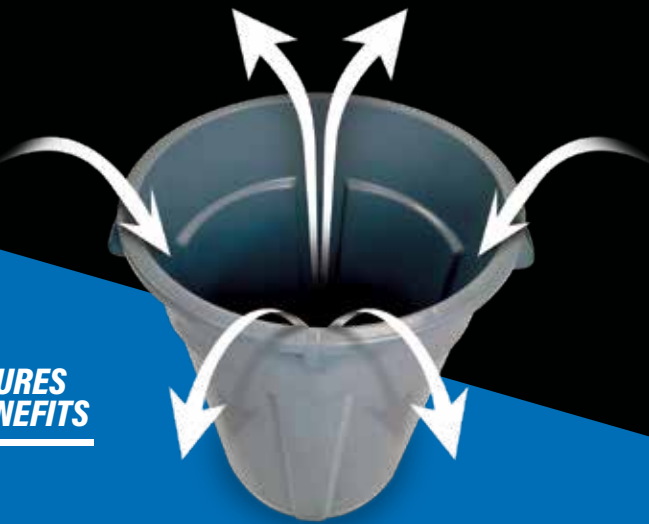

AIR CHANNELS

allow for optimal airflow in and out of the trash can, making bag removal and trash can stacking a breeze, not a time consuming challenge.



BAG CINCHES

help secure your bag to eliminate poor fitment and messy clean up.



MASSIVE REINFORCEMENT

for added strength and long-lasting durability.



32G

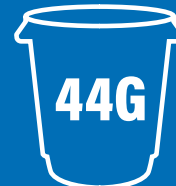

44G



55G

SEE ALL SIZES, COLORS & ACCESSORIES | PG. 11

PRO SERIES

TRASH CANS

- New sizes and colors! Now available in 32, 44 & 55 gallon capacities, each offered in three colors (Gray, Yellow and Red)
- Air channels maximize airflow to reduce suction and make bag removal a breeze
- Built-in bag cinches to secure liner
- Massively reinforced, jobsite ready trash cans
- Ergonomic built-in handles for comfort and easy handling
- Lids and dollies available as optional accessories



MATERIAL HANDLING

ITEM CODE	DESCRIPTION	SIZE	COLOR	SHIPPING DIMENSIONS	ITEM WEIGHT	PALLET COUNT	PURCHASE UNIT
CMTC-C-32G	PRO SERIES TRASH CAN	32 GALLON	GRAY	26" X 22" X 28"	9 LB	48	1 TRASH CAN
CMTC-C-44G	PRO SERIES TRASH CAN	44 GALLON	GRAY	28" X 24" X 31"	11.6 LB	48	1 TRASH CAN
CMTC-C-55G	PRO SERIES TRASH CAN	55 GALLON	GRAY	30" X 27" X 33"	15.2 LB	48	1 TRASH CAN
CMTC-C-32Y	PRO SERIES TRASH CAN	32 GALLON	YELLOW	26" X 22" X 28"	9 LB	48	1 TRASH CAN
CMTC-C-44Y	PRO SERIES TRASH CAN	44 GALLON	YELLOW	28" X 24" X 31"	11.6 LB	48	1 TRASH CAN
CMTC-C-55Y	PRO SERIES TRASH CAN	55 GALLON	YELLOW	30" X 27" X 33"	15.2 LB	48	1 TRASH CAN
CMTC-C-32R	PRO SERIES TRASH CAN	32 GALLON	RED	26" X 22" X 28"	9 LB	48	1 TRASH CAN
CMTC-C-44R	PRO SERIES TRASH CAN	44 GALLON	RED	28" X 24" X 31"	11.6 LB	48	1 TRASH CAN
CMTC-C-55R	PRO SERIES TRASH CAN	55 GALLON	RED	30" X 27" X 33"	15.2 LB	48	1 TRASH CAN

PRO SERIES

TRASH CAN LIDS

- Great fitment on Pro Series Trash Cans
- Securely snaps shut and opens easily
- Available in all sizes and colors



ITEM CODE	DESCRIPTION	SIZE	COLOR	ITEM WEIGHT	BOX COUNT	PURCHASE UNIT
CMTC-L-32G	PRO SERIES TRASH CAN LID	32G	GRAY	2 LB	10	1 LID
CMTC-L-44G	PRO SERIES TRASH CAN LID	44G	GRAY	2 LB	10	1 LID
CMTC-L-55G	PRO SERIES TRASH CAN LID	55G	GRAY	3.2 LB	10	1 LID
CMTC-L-32Y	PRO SERIES TRASH CAN LID	32G	YELLOW	2 LB	10	1 LID
CMTC-L-44Y	PRO SERIES TRASH CAN LID	44G	YELLOW	2 LB	10	1 LID
CMTC-L-55Y	PRO SERIES TRASH CAN LID	55G	YELLOW	3.2 LB	10	1 LID
CMTC-L-32R	PRO SERIES TRASH CAN LID	32G	RED	2 LB	10	1 LID
CMTC-L-44R	PRO SERIES TRASH CAN LID	44G	RED	2 LB	10	1 LID
CMTC-L-55R	PRO SERIES TRASH CAN LID	55G	RED	3.2 LB	10	1 LID

HEAVY-DUTY UNIVERSAL TRASH CAN DOLLY

Universal design. One size fits all Pro Series Trash Cans and most major brand trash cans. Designed with massive structural reinforcements for improved longevity and transportation of heavy refuse.



Smooth rolling, non-marking casters

ITEM CODE	DESCRIPTION	COLOR	WEIGHT	BOX COUNT	PURCHASE UNIT
CATC-DG-HD	H.D. 20/32/44/55G TRASH CAN DOLLY	GRAY	6.9 LB	6	1 DOLLY



PRO SERIES

COMMERCIAL DRYWALL CART

Commercial grade, high-capacity cart that handles 3,200 lb loads. The extra-large, sloped deck manages heavy materials while reducing the risk of slipping and tipping. The welded steel cart frame has a powder coat finish that guards against corrosion and withstands the elements. Magnum also offers a variety of compatible casters that meet the needs of any demanding environment.

- 40" x 12" Steel Plate
- High quality powder coated finish
- Available in four different caster configurations to meet virtually any demand
- Configuration shown: Max-Performance Casters
2 swivel casters & 2 swivel casters w/ locks (DOA3200-MP)



Shown w/
8" Max-Performance
Casters w/ Locks

CASTER OPTIONS

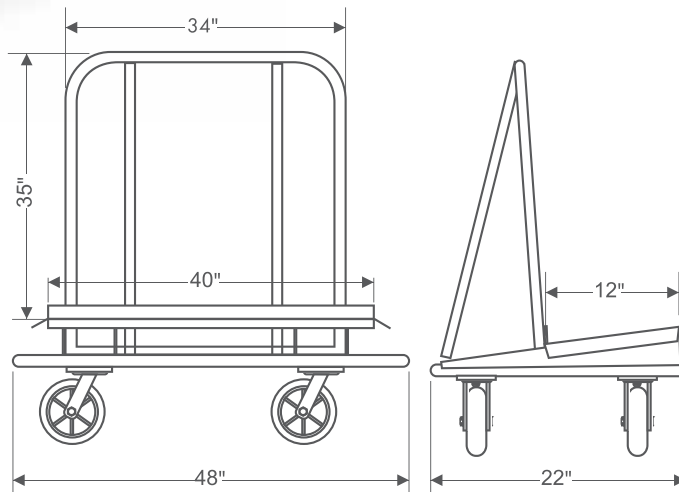

8" Max-Performance Polyurethane Casters w/ Locks & Brakes



8" Max-Endurance Polyurethane Casters



8" Standard Polyurethane Casters

ITEM CODE

DOA3200-MP

DOA3200-MX

DOA3200-PP

DOA3200-MP-PU

DESCRIPTION

PRO-SERIES COMMERCIAL DRYWALL CART W/ MAX-PERFORMANCE CASTERS W/ LOCKS

PRO-SERIES COMMERCIAL DRYWALL CART W/ MAX-PERFORMANCE CASTERS W/ LOCKS & BRAKES

PRO-SERIES COMMERCIAL DRYWALL CART W/ MAX-ENDURANCE CASTERS W/ LOCKS

PRO-SERIES COMMERCIAL DRYWALL CART W/ MAX-HARD POLYURETHANE CASTERS

LOAD CAPACITY

3200 LB

WEIGHT

85 LB

PALLET COUNT

12

PURCHASE UNIT

1 CART

86 LB

12

1 CART

3200 LB

88 LB

12

1 CART

3200 LB

96 LB

12

1 CART

PRO SERIES

RESIDENTIAL DRYWALL CART

- 39-3/4" x 9-3/8" Nylon Skid Plate over Steel
- High quality powder coated finish
- Compatible with Max-Performance Narrow Casters only
- 2 swivel casters and 2 swivel casters with locks

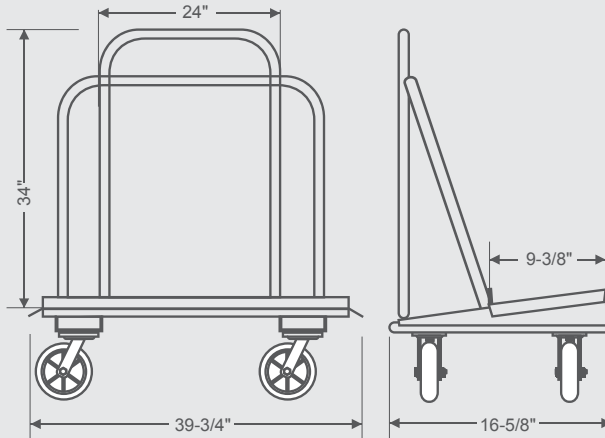

Max-Performance Narrow Casters

ITEM CODE	DESCRIPTION	LOAD CAPACITY	WEIGHT	PALLET/BOX COUNT	PURCHASE UNIT
DOR03	RESIDENTIAL DRYWALL CART W/ MAX-PERFORMANCE NARROW CASTERS	3200 LB	69 LB	12 PALLET	1 CART
 DOR03-P	NYLON REPLACEMENT PLATE FOR DOR03 (39-3/4" X 9-3/8" X 0.4")	N/A	3.7 LB	10 BOX	1 PLATE

FLAT CART

- 43" x 22" Steel Plate
- High quality powder coated finish
- Max-Performance Casters
- Includes 2 fixed casters, 1 swivel caster and 1 swivel caster w/ lock

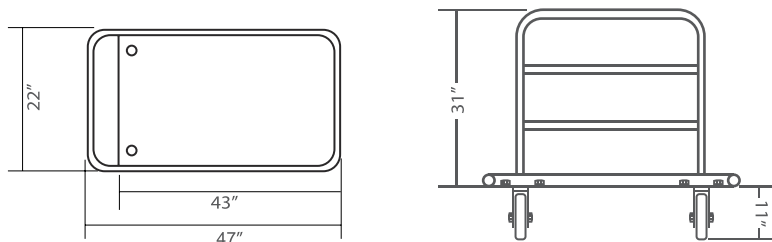

Max-Performance Casters

ITEM CODE	DESCRIPTION	LOAD CAPACITY	WEIGHT	PALLET COUNT	PURCHASE UNIT
CAF2247	FLAT CART W/ MAX-PERFORMANCE CASTERS	3200 LB	68 LB	20	1 CART





DO MORE. WITH LESS.

Transform one cart into many.



Dolly

Flat Cart

Drywall Cart

Stake Cart

Introducing the **Magnum Transformer Cart**, a do-all material cart that transforms into a variety of useful haulers. No tools required. Simply grab the handles you want and go. Handles stow flat into the frame when you convert to Dolly mode. Connect two units together to form a 10' train, or connect side by side to create a 5'X4' platform. Get ready to make the most out of your cart and move some serious material. Transform the way you work, and get more done with less.



DOA4X



EASY HANDLE POSITIONING

Utilize quick-release pins to put the handles where you need them. There are six different handle mounting points.



MAX-ENDURANCE POLYURETHANE CASTERS

These hard polyurethane casters have been designed to hold up to a 5400 LB load capacity when two carts are connected and the weight is distributed evenly.

NEW MAGNUM TRANSFORMER CART

46.5" L X 27" W X 48" H
(With casters and handles)

- Easily transforms this cart into a Dolly, Flat Cart, Drywall Cart & Stake Cart, without the use of tools.
- All handles store into frame to make transport and storage easy.
- High quality steel construction w/ durable powder coated finish
- Ability to connect two carts together end-to-end, or side-by-side.
- 8" Max-Performance Casters for a premium ride and excellent maneuverability, or 8" Max-Endurance Hard Polyurethane Caster to handle the heaviest of loads.

ITEM CODE	DESCRIPTION	LOAD CAPACITY	WEIGHT	PALLET/BOX COUNT	PURCHASE UNIT
DOA4X-MP	TRANSFORMER CART W/ 8" MAX-PERFORMANCE CASTERS	3200 LB	123 LB	10 PALLET	1 CART
DOA4X-PP	TRANSFORMER CART W/ 8" MAX-ENDURANCE POLYURETHANE CASTERS	3200 LB	126 LB	10 PALLET	1 CART
 DOA4X-P	NYLON REPLACEMENT PLATE FOR DOA4X (DIMS. 46.5" X 14")	N/A	9 LB	10 BOX	1 PLATE

NEW ACCESSORY



DOA4X-A-PR

Pipe Rack Attachment for Transformer Cart



*Cart & casters sold separately

Convert your Transformer Cart into a Pipe Cart. Carry 400 LBS per rung (200 LB max. per side).



Part of our Pro Series offering, Max-Performance Casters and the Max-Endurance Casters are each designed to withstand daily punishment on the jobsite and provide increased performance and reliability. Max-Performance Casters are super smooth and easily maneuverable, whereas Max-Endurance Casters are hard Polyurethane and built to endure the heaviest of loads.

Max Casters are designed to distribute the load weight across the entire width of the hub, rather than focus the weight in the center of the hub. This principle design changes means a longer lasting caster with increased performance, reliability and durability. These non-marking casters will not pick up debris from the floor surface or fall apart prematurely like the competitors.

PRO SERIES

TAKE YOUR CASTERS TO THE

MAX

**PRO SERIES
MAX-PERFORMANCE CASTERS**

- Smoothest rolling and easiest maneuverability
- Will not collect unwanted floor debris in wheel surface
- Non-marking, and safe to all surfaces
- Holds up to maximum load capacity without warping and losing shape



DO-AB

ITEM CODE	DESCRIPTION	BOX DIMENSIONS	LOAD CAPACITY PER CASTER	BOX WEIGHT	PURCHASE UNIT
DO-AB	8" PRO SERIES MAX-PERFORMANCE CASTER KIT - 2 SWIVEL W/ LOCK, 2 SWIVEL	24.5" X 10.5" X 4.5"	800 LB	24.5 LB	1 KIT
DO-AB3	8" PRO SERIES MAX-PERFORMANCE NARROW CASTER KIT - 2 SWIVEL W/ LOCK, 2 SWIVEL		800 LB	24.1 LB	1 KIT
DO-ABX	8" PRO SERIES MAX-PERFORMANCE CASTER KIT W/ 16 BOLTS - 2 SWIVEL W/ BRAKE & LOCK, 2 SWIVEL W/ LOCK AND 16 BOLTS		800 LB	26 LB	1 KIT
CAFM-A	8" PRO SERIES MAX-PERFORMANCE FLAT CART CASTER KIT - 1 SWIVEL W/ LOCK, 2 FIXED, 1 SWIVEL		800 LB	21 LB	1 KIT

**NEW PRO SERIES
MAX-ENDURANCE CASTERS**

- Hard Polyurethane for maximum durability under heavy loads
- Will not collect unwanted floor debris in wheel surface
- Non-marking, and safe to all surfaces

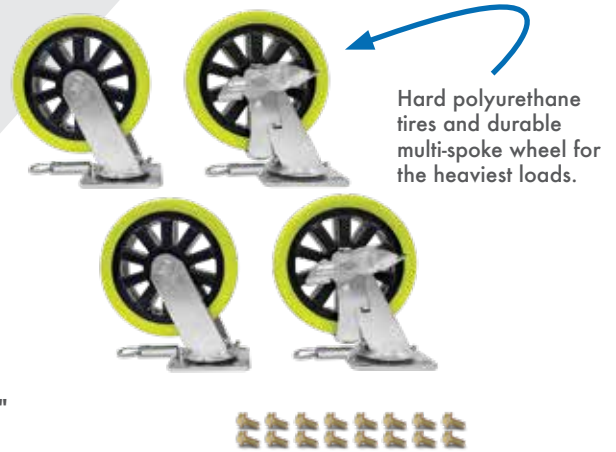

DO-APP

8" Pro Series Max-Endurance Polyurethane Caster Kit

(2 swivel w/ brake & lock, 2 swivel w/ lock, 16 bolts)

LOAD CAPACITY	900 LB PER CASTER
BOX WEIGHT	31 LB
BOX DIMENSIONS	24.5" X 10.5" X 4.5"
PURCHASE UNIT	1 KIT



**DO-A
8" Standard Non-Marking Caster Kit**

(2 swivel w/ lock, 2 swivel)

LOAD CAPACITY	800 LB PER CASTER
BOX WEIGHT	25 LB
BOX DIMENSIONS	24.5" X 10.5" X 4.5"
PURCHASE UNIT	1 KIT



**DO-APU
8" Polyurethane Caster Kit**

(2 swivel w/ lock, 2 swivel)











LOAD CAPACITY	800 LB PER CASTER
BOX WEIGHT	36 LB
BOX DIMENSIONS	24.5" X 10.5" X 4.5"
PURCHASE UNIT	1 KIT



MATERIAL CART CASTER KIT FITMENT GUIDE

Use this guide to find the right casters for your Material Cart. Get additional caster kit details on the previous page.

WHAT FITS WHAT?

		DOA3200 	DOR03 	DOA4X 	CAFM2247 
DO-AB 8" PRO SERIES MAX-PERFORMANCE CASTER KIT 2 swivel w/ lock, 2 swivel 	● STANDARD	✗ DOES NOT FIT	✓ FITS	✓ FITS	
DO-AB3 8" PRO SERIES MAX-PERFORMANCE NARROW CASTER KIT 2 swivel w/ lock, 2 swivel 	✓ FITS	● STANDARD	✓ FITS	✓ FITS	
DO-ABX 8" PRO SERIES MAX-PERFORMANCE CASTER KIT W/BOLTS 2 swivel w/ brake & lock, 2 swivel w/ lock, 16 bolts 	✓ FITS	✗ DOES NOT FIT	● STANDARD ON DOA4X-MP	✓ FITS	
CAFM-A 8" PRO SERIES MAX-PERFORMANCE FLAT CART CASTER KIT 1 swivel w/ lock, 1 swivel, 2 fixed 	✓ FITS	✗ DOES NOT FIT	✓ FITS	● STANDARD	
DO-A 8" STANDARD NON-MARKING CASTER KIT 2 swivel w/ lock, 2 swivel 	✓ FITS	✗ DOES NOT FIT	✓ FITS	✓ FITS	
DO-APU 8" POLYURETHANE CASTER KIT 2 swivel w/ lock, 2 swivel 	✓ FITS	✗ DOES NOT FIT	✓ FITS	✓ FITS	
DO-APP 8" PRO SERIES MAX-ENDURANCE CASTER KIT W/ BOLTS 2 swivel w/ brake & lock, 2 swivel w/ lock, 16 bolts 	✓ FITS	✗ DOES NOT FIT	● STANDARD ON DOA4X-PP	✓ FITS	



BUILT FOR VERSATILITY

Adapt this cart for virtually any environment. Position the handle the way you want and utilize the many fastening points around the cart to hold just about anything you want. Choose from an array of 5" or 8" casters to tackle what you want. Secure your valuables and keep productivity up. The versatility is endless.

CHANGE YOUR HANDLE POSITION

INSERT A POLE TOOL

HOLD & CUT ROUND OR SQUARE MATERIAL

STORE A BEVERAGE

HANG A LADDER OR TRASH CAN

STORE SCREW DRIVERS

INSERT OUR ACCESSORIES

VAULT
TOOL BOX

HANG CORD

INSERT OUR TOOL HOOK ACCESSORY

CHARGE SECURELY

KEEP IT SAFE

CHOOSE A CASTER OPTION FROM 5", 8" or 9" (5" HD SHOWN).

4426 PRO SERIES

ADAPTABLE SERVICE CART

44" x 25"

4426 PRO SERIES 2-Shelf Adaptable Service Carts

- Adaptable handle can be positioned flat or ergonomically to suit the user
- Two deep tray shelves to keep things in place
- Tough polypropylene structural foam construction for years of rugged dependability
- V-Cut securely holds material to assist with accurate measuring and cutting
- Mounting points for hooks, poles, tools and other handy accessories
- Easily attach Vault Security Paneling or Vault Tool Box for added safety and security



CASTER OPTIONS



5" STANDARD NON-MARKING

5" HEAVY-DUTY NON-MARKING

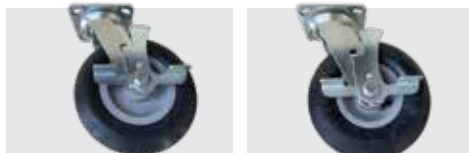

8" FLAT-FREE

8" PNEUMATIC/AIR



9" FLAT-FREE

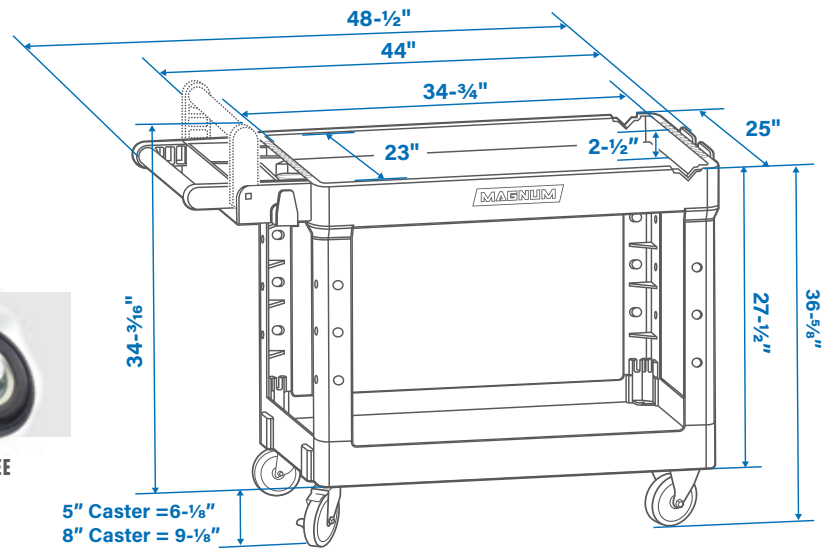

5" Caster = 6-1/8"
8" Caster = 9-1/8"

ITEM CODE

INCLUDES

LOAD CAPACITY ITEM WEIGHT BOX COUNT

CART4426-PRO-A5S	4426 PRO SERIES CART W/ 5" NON-MARKING CASTERS (2 FIXED, 2 SWIVEL)	500 LB	54 LB	1 CART
CART4426-PRO-A5H	4426 PRO SERIES CART W/ 5" HEAVY-DUTY CASTERS (2 FIXED, 2 SWIVEL W/BRAKE)	500 LB	57 LB	1 CART
CART4426-PRO-A8N	4426 PRO SERIES CART W/ 8" FLAT-FREE CASTERS (2 FIXED, 2 SWIVEL W/BRAKE)	500 LB	73 LB	1 CART
CART4426-PRO-A8A	4426 PRO SERIES CART W/ 8" PNEUMATIC CASTERS (2 FIXED, 2 SWIVEL W/BRAKE)	500 LB	71.2 LB	1 CART
CART4426-PRO-A9N	4426 PRO SERIES CART W/ 9" FLAT-FREE CASTERS (2 FIXED, 2 SWIVEL)	500 LB	78 LB	1 CART



4117 PRO SERIES

ADAPTABLE SERVICE CART

41" x 17"

4117 PRO SERIES 2-Shelf Adaptable Service Cart w/ V-Cut

- Adaptable handle can be positioned flat or ergonomically to suit the user
- Narrow width to maneuver in confined spaces
- Two deep tray shelves to keep things in place
- Tough polypropylene structural foam construction for years of rugged dependability
- V-Cut securely holds material to assist with accurate measuring and cutting
- Mounting points for hooks, poles, tools and other handy accessories (2 Free Tool Hooks included)
- Easily attach Vault Tool Box for added storage and security

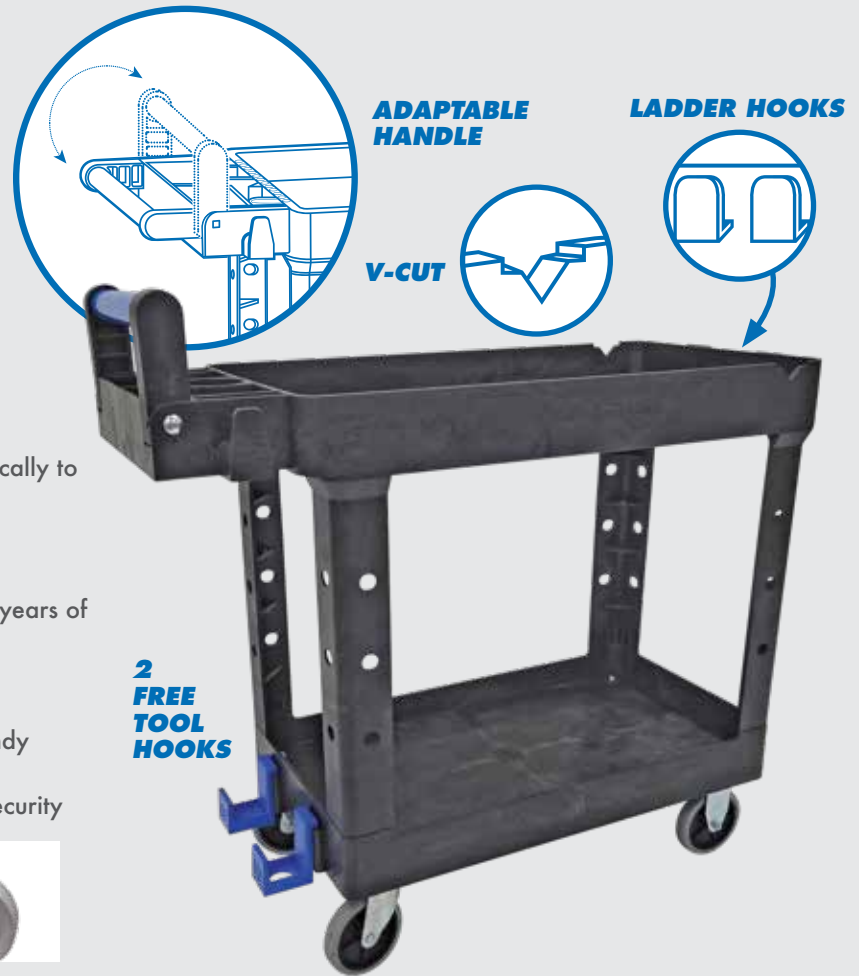

CASTER OPTIONS



5" NON-MARKING

5" HEAVY-DUTY

ITEM CODE	DESCRIPTION	INCLUDES VAULT:	LOAD CAPACITY	ITEM WEIGHT	PURCHASE UNIT
CART4117-PRO-A5S	4117 CART W/ 5" NON-MARKING CASTERS (2 FIXED, 2 SWIVEL)	NO	500 LB	29.8 LB	1 CART
CART4117-PRO-A5H	4117 CART W/ 5" HEAVY-DUTY CASTERS (2 FIXED, 2 SWIVEL W/BRAKE)	NO	500 LB	32.3 LB	1 CART
CART-K05	4117 CART W/ 5" HEAVY-DUTY CASTERS (2 FIXED, 2 SWIVEL W/BRAKE)	VAULT TOOL BOX	500 LB	58 LB	1 KIT

NEW

4117 UTILITY

ADAPTABLE SERVICE CART

41" x 17"

4117 Utility 2-Shelf Adaptable Service Cart

- Adaptable handle can be positioned flat or ergonomically to suit the user
- Narrow width to maneuver in confined spaces
- Two deep tray shelves to keep things in place
- Tough polypropylene structural foam construction for years of rugged dependability
- Easily attach Vault Tool Box for added storage and security



ITEM CODE	DESCRIPTION	INCLUDES VAULT:	LOAD CAPACITY	ITEM WEIGHT	PURCHASE UNIT
CART4117-UTY-A5S	4117 CART W/ 5" NON-MARKING CASTERS (2 FIXED, 2 SWIVEL)	NO	500 LB	28.1 LB	1 CART

VAULT

SAFE & SECURE MOBILITY.

Secure your Service Cart. Keep your tools safe and secure by easily installing our heavy-duty Vault Security Paneling or a Vault Tool Box on our line of Service Carts.

More on Vault throughout this section of the catalog.



HEAVY-DUTY 16G STEEL WITH DURABLE POWDER COATED FINISH



KEEP YOUR TOOLS LOCKED-UP & STILL CHARGING WHEN NOT IN USE

 **FITS MAGNUM, SURPRO & RUBBERMAID* CART #4520-88**

 **AVAILABLE IN SECURITY PANELING OR TOOL BOX VERSIONS**

 **KEEPS TOOLS SAFE & SECURE**



VAULT SECURITY PANELING

VAULT TOOL BOX

ITEM CODE	DESCRIPTION	ITEM WEIGHT	BOX WEIGHT	BOX DIMENSIONS	PURCHASE UNIT
CART4426-VS	VAULT SECURITY PANELING FOR 4426 PRO SERIES SERVICE CART	41 LB	49 LB	45" X 27" X 7"	1
CART4426-BS	VAULT TOOL BOX FOR 4426 PRO SERIES SERVICE CART	37 LB	43 LB	34" X 15.5" X 12"	1
CART4117-BS	VAULT TOOL BOX (SMALL) FOR ALL 4117 SERVICE CARTS	25 LB	28 LB	29" X 22" X 5"	1

*Vault Security Paneling and Vault Tool Box shown on 4426 Pro Series Cart. Vault Security Paneling not available for 4117 Service Carts. Tools, ladders, and accessories shown in photo are for illustrative purposes only. Rubbermaid is a trademark of its respective owner. Use of the trademark does not imply any affiliation with or endorsement by them.

BUNDLE & SAVE

PRO SERIES

ADAPTABLE SERVICE CART

+ VAULT



CART-K09
4426 PRO SERIES CART
+ VAULT SECURITY PANELING



CART-K10
PRO SERIES CART
+ VAULT TOOL BOX

Bundle the 4426 Pro Series Service Cart with your choice of Vault Security Paneling or Vault Tool Box, and receive a discount when purchased together as a kit. Choose from a variety of 5", 8" or 9" Caster options and tackle any obstacle. Build a narrower cart by choosing the 4117 Pro Series Service Cart with Vault Tool Box.

- Keep your assets secure
- Keep certain tools and supplies locked up safely
- Ensure that your tools are where you need them, when you need them
- Assembly required

PRO SERIES 2-Shelf Adaptable Service Carts w/ Vault Kits

ITEM CODE	DESCRIPTION		KIT WEIGHT	PURCHASE UNIT
CART-K09	4426 PRO SERIES CART W/ 5" HEAVY-DUTY CASTERS (2 FIXED, 2 SWIVEL W/BRAKE)	+ VAULT SECURITY PANELING	98 LB	1 KIT
CART-K10	4426 PRO SERIES CART W/ 5" HEAVY-DUTY CASTERS (2 FIXED, 2 SWIVEL W/BRAKE)	+ VAULT TOOL BOX	82 LB	1 KIT
CART-K11	4426 PRO SERIES CART W/ 8" FLAT-FREE CASTERS (2 FIXED, 2 SWIVEL W/BRAKE)	+ VAULT SECURITY PANELING	114 LB	1 KIT
CART-K12	4426 PRO SERIES CART W/ 8" FLAT-FREE CASTERS (2 FIXED, 2 SWIVEL W/BRAKE)	+ VAULT TOOL BOX	110 LB	1 KIT
CART-K13	4426 PRO SERIES CART W/ 8" PNEUMATIC CASTERS (2 FIXED, 2 SWIVEL W/BRAKE)	+ VAULT SECURITY PANELING	112 LB	1 KIT
CART-K14	4426 PRO SERIES CART W/ 8" PNEUMATIC CASTERS (2 FIXED, 2 SWIVEL W/BRAKE)	+ VAULT TOOL BOX	108 LB	1 KIT
CART-K18	4426 PRO SERIES CART W/ 9" FLAT-FREE CASTERS (2 FIXED, 2 SWIVEL)	VAULT SECURITY PANELING	119 LB	1 KIT
CART-K19	4426 PRO SERIES CART W/ 9" FLAT-FREE CASTERS (2 FIXED, 2 SWIVEL)	VAULT TOOL BOX	115 LB	1 KIT
CART-K05	4117 PRO SERIES CART W/ 5" HEAVY-DUTY CASTERS (2 FIXED, 2 SWIVEL W/BRAKE)	+ VAULT TOOL BOX	58 LB	1 KIT

NEW

DRAFTDECK

PLANNER TABLE FOR SERVICE CARTS

The **Magnum DraftDeck Planner Table** is a versatile accessory for our 4426 Pro Series Service Cart. It converts the upper tray into a secure storage area and flat workspace. The flip-top lid positions at two ergonomic angles for easy document review and collaboration. For standard use, stow the lid against the cart side. Lightweight, durable, and easy to mount or remove with 12 P3 screws, it's perfect for all construction phases. Enhance productivity with adaptable work angles, secure storage, and robust design.

- 37" X 26-1/2" table top surface
- Fits Magnum 4426 Pro Series Service Carts (works with or without Magnum Vault installed)
- Flip-Top lid can be positioned at a variety of angles to make collaboration easier
- Use a key or combination lock to secure the contents of your upper tray
- Service Cart & Vault sold separately



PLAN AND REVIEW DOCUMENTS



KEEP ITEMS SAFE AND SECURE



ROTATE LID TO DESIRED POSITION



ITEM CODE	DESCRIPTION	LENGTH	WIDTH	HEIGHT	ITEM WEIGHT	PALLET COUNT	PURCHASE UNIT
CART4426-DD	MAGNUM DRAFTDECK PLANNER TABLE	37 IN	26-1/2 IN	2-1/8 IN	14 LB	44	1 DRAFTDECK





5" Standard Non-Marking Casters

Standard non-marking casters.

ITEM CODE	DESCRIPTION	CASTER SIZE	WEIGHT	PURCHASE UNIT
CASU5-F	STANDARD CASTERS - FIXED	5" X 1"	0.9 LB	1 CASTER
CASU5-S	STANDARD CASTERS - SWIVEL	5" X 1"	1.1 LB	1 CASTER
CARTA-A5S	STANDARD CASTER KIT - 2 STANDARD FIXED, 2 STANDARD SWIVEL AND SCREW HARDWARE	5" X 1"	5 LB	1 SET



5" Heavy-Duty Non-Marking Casters

Heavy-duty, non-marking casters.

ITEM CODE	DESCRIPTION	CASTER SIZE	WEIGHT	PURCHASE UNIT
CASU5-F-HD	HEAVY-DUTY CASTERS - FIXED	5" X 1-1/4"	1.43 LB	1 CASTER
CASU5-BR-HD	HEAVY-DUTY CASTERS - SWIVEL W/ BRAKE	5" X 1-1/4"	2.09 LB	1 CASTER
CARTA-A5H	HEAVY-DUTY CASTER KIT - 2 FIXED, 2 SWIVEL W/ BRAKE AND SCREW HARDWARE	5" X 1-1/4"	7.92 LB	1 SET

8" Heavy-Duty Flat-Free Casters

Fits service carts. Flat-free casters large enough to roll over obstacles easier, and provide added floor protection. 3" X 3" bolt pattern on plate.



ITEM CODE	DESCRIPTION	CASTER SIZE	WEIGHT	PURCHASE UNIT
CASU8N-F	FLAT-FREE CASTER - FIXED	8" X 2"	4 LB	1 CASTER
CASU8N-BR	FLAT-FREE CASTER - SWIVEL W/ BRAKE	8" X 2"	6 LB	1 CASTER
CARTA-A8N	FLAT-FREE CASTER SET - 2 FIXED, 2 SWIVEL W/ BRAKE AND SCREW HARDWARE	8" X 2"	22 LB	1 SET

8" Heavy-Duty Pneumatic/Air Casters

Fits service carts. Pneumatic/air casters provide better traction and a smoother ride. The shock-absorbing ride helps protect valuable cargo. 3" X 3" bolt pattern on plate.



ITEM CODE	DESCRIPTION	CASTER SIZE	WEIGHT	PURCHASE UNIT
CASU8A-F	PNEUMATIC/AIR CASTER - FIXED	8" X 2"	3.5 LB	1 CASTER
CASU8A-BR	PNEUMATIC/AIR CASTER - SWIVEL W/ BRAKE	8" X 2"	5.3 LB	1 CASTER
CARTA-A8A	PNEUMATIC/AIR CASTER SET - 2 FIXED, SWIVEL W/ BRAKE AND SCREW HARDWARE	8" X 2"	20.2	1 SET



9" Heavy-Duty Flat-Free Casters

Fits service carts. Flat-free casters large enough to roll over obstacles easier, and provide added floor protection.

ITEM CODE	DESCRIPTION	CASTER SIZE	WEIGHT	PURCHASE UNIT
CAS9-NF-WF-N	CASTERS - FIXED	9" X 3"	6 LB	1 CASTER
CAS9-NF-WS-N	CASTERS - SWIVEL	9" X 3"	7 LB	1 CASTER
CARTA-A9N	CASTER KIT - 2 FIXED, 2 SWIVEL	9" X 3"	26 LB	1 SET

SERVICE CART ACCESSORIES

Want to hook your service cart up with handy accessories? Just clip on these and go! Super convenient for transporting poles, tools, ladders, and cords.



TIR10H
EPDM TIE DOWNS

Keep your ladder secure on our built in cart hooks, or Tool Hook accessories. Not sold individually. Included in our Service Ladder Kits below (CARTA-L & CARTA-TPL).



CARTA-22H
Tool Hook w/ Hole

Attach to the top or bottom shelf. Use as a hook, as well as, a pole tool holder when used in conjunction with CARTA-22 as a pole tool base.



CARTA-22
Tool Hook

Attach to the top or bottom shelf. Use as a hook and most commonly as a pole tool base when used in conjunction with CARTA-22H.



OUT3USB
Power Strip

3-Outlet Power Strip with 2 USB Ports and 9' Cord.

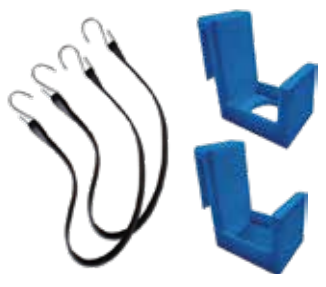

CARTA-L
Service Cart Ladder Hook Kit

Includes:
(2) EPDM Tie Downs
(1) Tool Hook w/ Hole
(1) Tool Hook



CARTA-TP
Service Cart Tool & Pole Hook Kit

Includes:
(2) Tool Hooks w/ Hole
(2) Tool Hooks



CARTA-TPL
Service Cart Ladder, Tool & Pole Hook Kit

Includes:
(2) EPDM Tie Downs
(4) Tool Hooks w/ Hole
(4) Tool Hooks



6 CU. FT. STEEL DUAL WHEEL WHEELBARROWS

- 6 cubic feet capacity
- Dual wheels offer better balance
- Heavy-duty 12 gauge steel tray
- Reinforced tray braces
- 16" Pneumatic or Flat-free tires
- Steel or wood handles

DUAL WHEELS

offer better balance when carrying heavier loads.



Flat-Free

Pneumatic

ITEM CODE	DESCRIPTION	WHEEL/ TIRE SIZE	LOAD CAPACITY	ITEM WEIGHT	PURCHASE UNIT
BAWH6-SHA-2	6 CU. FT. STEEL WHEELBARROW W/ DUAL PNEUMATIC TIRES (STEEL HANDLE)	16"	6 CU. FT.	55 LB	1
BAWH6-SHF-2	6 CU. FT. STEEL WHEELBARROW W/ DUAL FLAT-FREE TIRES (STEEL HANDLE)	16"	6 CU. FT.	59 LB	1
BAWH6-WHA-2	6 CU. FT. STEEL WHEELBARROW W/ DUAL PNEUMATIC TIRES (WOOD HANDLE)	16"	6 CU. FT.	53 LB	1
BAWH6-WHF-2	6 CU. FT. STEEL WHEELBARROW W/ DUAL FLAT-FREE TIRES (WOOD HANDLE)	16"	6 CU. FT.	57 LB	1

6 CU. FT STEEL WHEELBARROWS

- 6 cubic feet capacity
- Heavy-duty 12 gauge steel tray
- Reinforced tray braces
- 16" Pneumatic or Flat-free tires
- Steel or wood handles

SINGLE WHEEL

offers better maneuverability when cornering.



Flat-Free

WOOD

ITEM CODE	DESCRIPTION	WHEEL/ TIRE SIZE	LOAD CAPACITY	ITEM WEIGHT	PURCHASE UNIT
BAWH6-SHA	6 CU. FT. STEEL WHEELBARROW W/ PNEUMATIC TIRE (STEEL HANDLE)	16"	6 CU. FT.	49 LB	1
BAWH6-SHF	6 CU. FT. STEEL WHEELBARROW W/ FLAT-FREE TIRE (STEEL HANDLE)	16"	6 CU. FT.	50 LB	1
BAWH6-WHA	6 CU. FT. STEEL WHEELBARROW W/ PNEUMATIC TIRE (WOOD HANDLE)	16"	6 CU. FT.	46 LB	1
BAWH6-WHF	6 CU. FT. STEEL WHEELBARROW W/ FLAT-FREE TIRE (WOOD HANDLE)	16"	6 CU. FT.	47 LB	1



DUAL WHEEL WHEELBARROW CONVERSION KITS

Convert a single wheel wheelbarrow into a dual wheel wheelbarrow. Kit assumes that you already have one wheel.

- (1) Wheel - Choose Pneumatic or Flat-Free
- (2) Axle Brackets
- (2) Hair Pins
- (4) Washers
- (1) Long Axle



ITEM CODE	DESCRIPTION	DIAMETER	WIDTH	WEIGHT	BOX COUNT	PURCHASE UNIT
BAWH6-2A	DUAL PNEUMATIC TIRE CONVERSION KIT - 1 PNEUMATIC TIRE/WHEEL, 2 AXLE BRACKETS, 2 HAIR PINS, 4 WASHERS, 1 LONG AXLE	16"	4"	5.3 LB	4	1 TIRE
BAWH6-2F	DUAL FLAT-FREE TIRE CONVERSION KIT - 1 FLAT-FREE TIRE/WHEEL, 2 AXLE BRACKETS, 2 HAIR PINS, 4 WASHERS, 1 LONG AXLE	16"	4"	6.4 LB	4	1 TIRE



WHEELBARROW TIRE/WHEEL

ITEM CODE	DESCRIPTION	DIAMETER	WIDTH	WEIGHT	BOX COUNT	PURCHASE UNIT
TIAK16-BB	PNEUMATIC TIRE/WHEEL (STEEL - BLACK)	16"	4"	5.3 LB	4	1 TIRE
TINK16-BC	FLAT-FREE TIRE/WHEEL (6-SPOKE METAL HUB)	16"	4"	6.4 LB	4	1 TIRE

*Tires/Wheels fit both Dual Wheelbarrows and Single Wheelbarrows.



WHEELBARROW REPLACEMENT HANDLES

ITEM CODE	DESCRIPTION	SIZE	WEIGHT	PURCHASE UNIT
HDWB	WHEELBARROW HANDLE, WOOD	59" X 1-1/2" X 1-3/4"	3.2 LB	1 PIECE
BAWH6-P3	WHEELBARROW HANDLE, STEEL	59" X 1-1/2" X 1-1/2"	4.4 LB	1 PIECE





ROUND GRIP STEM & SQUARE STEM CASTERS

6' Scaffold replacement casters

ITEM CODE	CASTER TYPE	WHEEL DIAMETER	WHEEL WIDTH	ITEM WEIGHT	BOX COUNT	PURCHASE UNIT
CAS5RL	ROUND STEM - SWIVEL W/ LOCK	5"	2"	3.5 LB	10	1 CASTER
CAS5SL	SQUARE STEM - SWIVEL W/ LOCK	5"	2"	4.4 LB	10	1 CASTER



THREADED STEM CASTERS

ITEM CODE	CASTER TYPE	CASTER DIAMETER	CASTER WIDTH	ITEM WEIGHT	BOX COUNT	PURCHASE UNIT
CAS3W	SWIVEL	3"	2"	1.43 LB	30	1 CASTER
CAS4W	SWIVEL	4"	2"	2 LB	20	1 CASTER



POLYPROPYLENE PLATE CASTERS

ITEM CODE	CASTER TYPE	CASTER DIAMETER	CASTER WIDTH	ITEM WEIGHT	BOX COUNT	PURCHASE UNIT
CAS4PF	FIXED	4"	2"	3.37 LB	20	1 CASTER
CAS4PS	SWIVEL	4"	2"	4.12 LB	20	1 CASTER
CAS4PS-NM	SWIVEL / NON-MARKING	4"	2"	4.6 LB	10	1 CASTER
CAS5PF	FIXED	5"	2"	3.8 LB	10	1 CASTER
CAS5PS	SWIVEL	5"	2"	4.6 LB	10	1 CASTER
CAS5PS-NM	SWIVEL / NON-MARKING	5"	2"	4.6 LB	10	1 CASTER
CAS6PF	FIXED	6"	2"	4.2 LB	10	1 CASTER
CAS6PS	SWIVEL	6"	2"	4.9 LB	10	1 CASTER



JOB BOX CASTER SETS

Set of four (4) Polypropylene casters. Fits Greenlee, Knaack and other manufacturers.

ITEM CODE	CASTER TYPE	CASTER DIAMETER	CASTER WIDTH	ITEM WEIGHT	BOX COUNT	PURCHASE UNIT
CAS4-K	4" CASTER SET - 2 SWIVEL/2 FIXED	4"	2"	16 LB	4	1 SET
CAS5-K	5" CASTER SET - 2 SWIVEL/2 FIXED	5"	2"	20 LB	4	1 SET
CAS6-K	6" CASTER SET - 2 SWIVEL/2 FIXED	6"	2"	24 LB	4	1 SET



PNEUMATIC (AIR) & FLAT-FREE CASTERS

Fits service carts. 8" x 2" casters. Available in Pneumatic (Air) and Flat-Free style.

ITEM CODE	CASTER TYPE	CASTER DIAMETER	CASTER WIDTH	ITEM WEIGHT	BOX COUNT	PURCHASE UNIT
CASU8A-BR	PNEUMATIC SWIVEL W/ BRAKE	8"	2"	5.3 LB	4	1 CASTER
CASU8A-F	PNEUMATIC FIXED	8"	2"	3.5 LB	4	1 CASTER
CASU8N-BR	FLAT-FREE SWIVEL W/ BRAKE	8"	2"	6 LB	4	1 CASTER
CASU8N-F	FLAT-FREE FIXED	8"	2"	4 LB	4	1 CASTER





9" CASTERS

Fits service carts. 9" x 3" Flat-Free casters.

ITEM CODE	CASTER TYPE	CASTER DIAMETER	CASTER WIDTH	ITEM WEIGHT	BOX COUNT	PURCHASE UNIT
CAS9-NF-WF-N	FIXED	9"	3"	6 LB	4	1 CASTER
CAS9-NF-WS-N	SWIVEL	9"	3"	7 LB	4	1 CASTER

See Fitment Guide on PG.17

PRO SERIES MAX-PERFORMANCE CASTERS

Our top-of-the-line Material Cart Casters built for easy maneuverability and longevity.



ITEM CODE	CASTER TYPE	CASTER DIAMETER	CASTER WIDTH	ITEM WEIGHT	BOX COUNT	PURCHASE UNIT
CAS800F-B	FIXED	8"	2"	4 LB	4	1 CASTER
CAS800S-B	SWIVEL	8"	2"	6 LB	4	1 CASTER
CAS800L-B	SWIVEL W/ LOCK	8"	2"	6.5 LB	4	1 CASTER
CAS800S-B3*	SWIVEL (NARROW PLATE)	8"	2"	3.7 LB	4	1 CASTER
CAS800L-B3*	SWIVEL W/ LOCK (NARROW PLATE)	8"	2"	5.7 LB	4	1 CASTER

*Narrow Plate Casters (XXXXXX-B3) are required on Residential Drywall Cart DOR03, and will also fit all other Material Carts.

PRO SERIES MAX-ENDURANCE CASTERS

Our top-of-the-line Polyurethane Material Cart Casters built for maximum durability.



ITEM CODE	CASTER TYPE	CASTER DIAMETER	CASTER WIDTH	ITEM WEIGHT	BOX COUNT	PURCHASE UNIT
CAS8PP-SLB	SWIVEL W/ LOCK & BRAKE	8"	2"	7 LB	4	1 CASTER
CAS8PP-SL	SWIVEL W/ LOCK	8"	2"	6 LB	4	1 CASTER

NON-MARKING CASTERS

Fits all Material Carts, except Residential Drywall Cart DOR03.



ITEM CODE	CASTER TYPE	CASTER DIAMETER	CASTER WIDTH	ITEM WEIGHT	BOX COUNT	PURCHASE UNIT
CAS800F-Y	FIXED	8"	2"	4 LB	4	1 CASTER
CAS800S-Y	SWIVEL	8"	2"	6 LB	4	1 CASTER
CAS800B-Y	SWIVEL W/ LOCK	8"	2"	6.5 LB	4	1 CASTER

STANDARD POLYURETHANE CASTERS

Fits all Material Carts, except Residential Drywall Cart DOR03.



ITEM CODE	CASTER TYPE	CASTER DIAMETER	CASTER WIDTH	ITEM WEIGHT	BOX COUNT	PURCHASE UNIT
CAS8FPU	FIXED W/ LOCK	8"	2"	8 LB	4	1 CASTER
CAS8SPU	SWIVEL	8"	2"	9 LB	4	1 CASTER
CAS8BPU	SWIVEL W/ LOCK	8"	2"	9 LB	4	1 CASTER



SAFE-ST

ITEM CODE

FIREBOX™

34" PORTABLE FIRE EXTINGUISHER STAND & SAFETY STATION

Stay in compliance and keep your jobsites and people safe with the Magnum Firebox- a flat-pack portable fire extinguisher stand that also serves as a safety station.

- Holds up to 30 LB Extinguisher
- Lightweight, sturdy and durable polypropylene construction for years of reliable use
- Flat-pack design for cost-effective shipping/transport and easy assembly/disassembly and storage
- EZ-Grip hand holds on all sides allows for one person to carry two units

ITEM CODE	ITEM WEIGHT	SHIPPING WEIGHT	SHIPPING DIMENSIONS	PALLET COUNT	PURCHASE UNIT
SAFE-ST	13 LB	16 LB	36"X21"X7"	32	1



MOUNT SAFETY ACCESSORIES ON ALL FOUR SIDES



Ready for screw mounting First Aid Kit, Eye Wash Station, Dust Masks and other safety supplies

OSHA COMPLIANT

1926.150 (A)(1,2,3,4) & (C)(1)(I), 1926.24, 1910.144 & 1910.157(C)

Patent Pending.

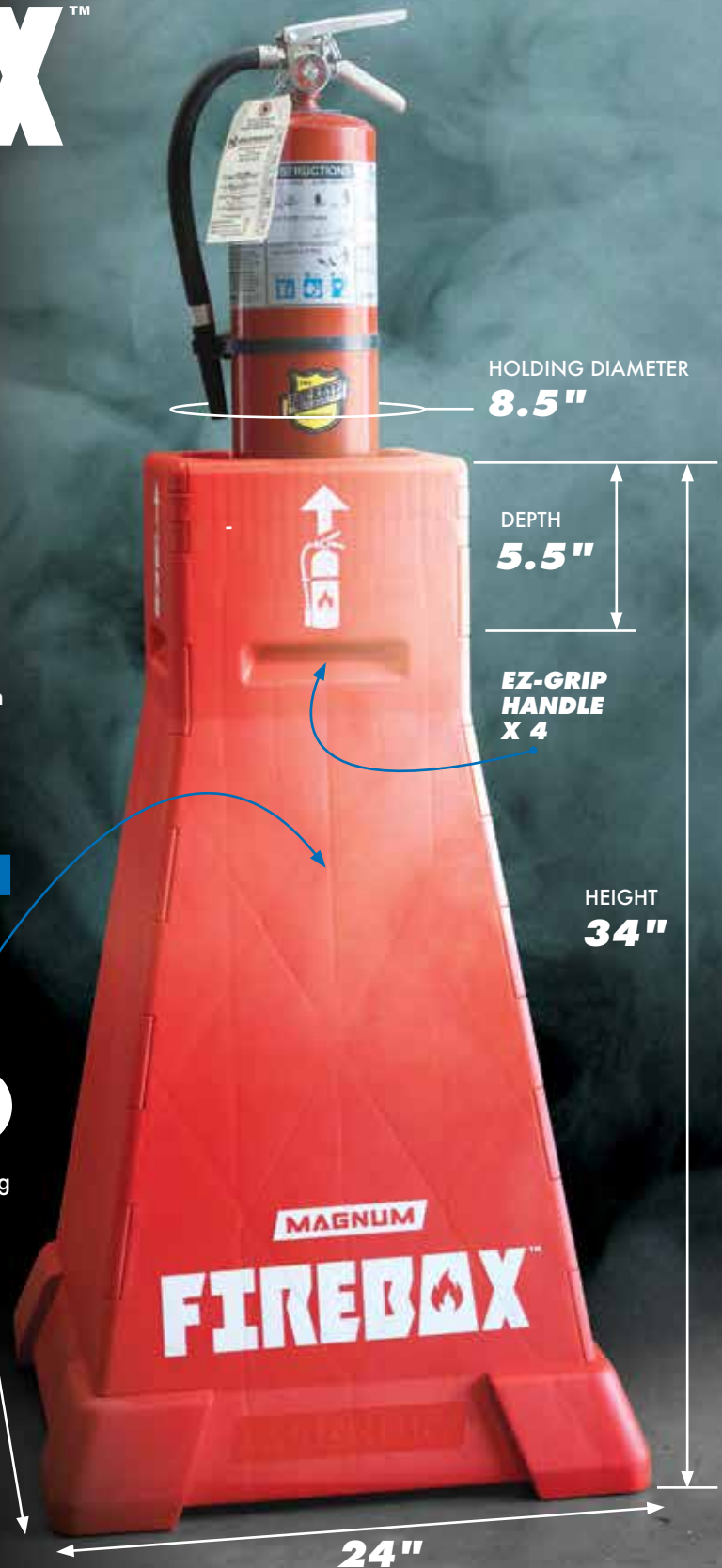

MAGNUMTM

WORK PLATFORMS



ALUMINUM STEP-UP BENCHES

- Extra Heavy-Duty Type 1A
- Bench top load capacity: **300 LB**
- Durable aluminum construction
- Extra-wide 10" split top
- Available in 2, 2.5, 3 & 4 ft
- Hex cap (partially threaded) bolts reduce joint wear and increase longevity of the product
- Double-rivets reinforce each step to provide added safety and security

Meets all OSHA requirements.

HEAVY-DUTY ALUMINUM

EXTRA WIDE 10" TOP



Safe and sturdy. Lightweight, yet rugged aluminum construction. Magnum Step-Up Benches are versatile step ladders, portable work platforms, sawhorses and benches, all-in-one. They fold up quickly for storage and transport. Used as a pair, they are a great solution for two-person jobs or for creating a large working surface.



ALUMINUM

STS2

STS212-3

STS3

STS4

	STS2	STS212-3	STS3	STS4
HEIGHT	2'	2.5'	3'	4'
LOAD CAPACITY	300 LB	300 LB	300 LB	300 LB
ITEM WEIGHT	12 LB	18.4 LB	20.5 LB	26 LB
PALLET COUNT	10 BENCHES	10 BENCHES	10 BENCHES	10 BENCHES
PURCHASE UNIT	1 BENCH	1 BENCH	1 BENCH	1 BENCH

MAGNUM



FIBERGLASS STEP-UP BENCHES

- Extra Heavy-Duty Type 1A
- Bench top load capacity: **300 LB**
- Non-conductive fiberglass legs
- Extra-wide 10" split top
- Available in 2, 2.5, 3 & 4 ft
- Double-rivets reinforce each step to provide added safety and security

Meets all OSHA requirements.

NON-CONDUCTIVE FIBERGLASS

EXTRA WIDE 10" TOP



Durable steel leg braces wrap around the bench top for added strength.



Reinforced fully-enclosed crossbeams add durability and increased stability.



No-slip, no-mark rubber feet with durable base frames.

Safe and sturdy. Non-conductive fiberglass legs and rugged aluminum construction. Steel top leg braces. Magnum Step-Up Benches are versatile step ladders, portable work platforms, sawhorses and benches, all-in-one. They fold up quickly for storage and transport. Used as a pair, they are a great solution for creating a large working surface.



FIBERGLASS

STS2-F

STS212-F3

STS3-F

STS4-F

HEIGHT	2'	2.5'	3'	4'
LOAD CAPACITY	300 LB	300 LB	300 LB	300 LB
ITEM WEIGHT	16.7 LB	22 LB	23.2 LB	29.7 LB
PALLET COUNT	10 BENCHES	10 BENCHES	10 BENCHES	10 BENCHES
PURCHASE UNIT	1 BENCH	1 BENCH	1 BENCH	1 BENCH



6' PORTABLE BAKER SCAFFOLD

SCF6B

- Dimensions: 73.5" L x 29" W x 75" H
- 1/2" Plywood Deck with Steel Frame
- 5" Swivel Casters with Brake
- Fits through Standard Doorways
- High-Quality Powder Coated Finish
- Compatible with other Baker Scaffold



CONVENIENT, SECURE, SPRING LOADED PLATFORM LOCK



SPRING LOADED D-HANDLE LOCKS FOR SAFE AND EASY HEIGHT ADJUSTMENT



HIGH QUALITY SPRING CLIPS & LOCKING PINS FOR ADDED SECURITY

Easy Stacking!

STACK TWO UNITS UP TO 12FT



1000 LB LOAD CAPACITY

OSHA
29 CFR Pt. 1926

ANSI
A10.8

CSA
S269.2 M87

ITEM CODE	DESCRIPTION	ITEM WEIGHT	ITEM DIMENSIONS	BOX DIMENSIONS	PALLET COUNT	PURCHASE UNIT
SCF6B	6' BAKER SCAFFOLD W/ STANDARD WALKBOARD	119 LB	73.5" X 29" X 75"	75" X 30" X 5.3"	12 UNITS	1 UNIT

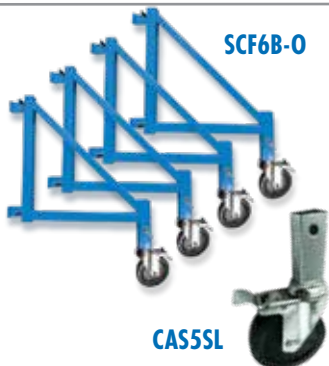

SCF6B-O

CAS5SL



SCF6B-G

PARTS & ACCESSORIES *

Quality replacement parts and accessories for 6' Baker Style Scaffold.

*Color of available accessories may vary.

ITEM CODE	DESCRIPTION	ITEM WEIGHT	BOX COUNT	PURCHASE UNIT
SCF6B-O	14" OUTRIGGERS	33 LB	4	1 PACK
CAS5SL	5" SWIVEL CASTER W/ BRAKE	4.4 LB	10	1 CASTER
SCF6B-G	GUARDRAIL SET	55 LB	1	1 SET
SCF6B-B	PLATFORM BRACES	16.5 LB	2	1 BRACE
SCF6B-F	SIDE FRAMES	17.6 LB	2	1 FRAME
SCF6B-H	WALKBOARD W/ ACCESS HATCH	33 LB	1	1 WALKBOARD
SCF6B-W	WALKBOARD, STANDARD	33 LB	1	1 WALKBOARD
SCF6B-P	LOCKING PIN	0.12 LB	40	1 PIN

MAGNUM

TM



WE'VE GOT YOU COVERED.

Rest assured that your purchase of Magnum Material Handling products is safe with the included one-year limited warranty. The Magnum Tool Corp., Inc. warranty protects against manufacturing defects from the date of purchase for an entire year. See warranty card for details and restrictions.

COAST-TO-COAST SUPPORT.

Magnum has dealers across the United States, Canada and abroad. Contact us to find a dealer near you. Don't hesitate to reach out with any questions you may have. We'll do our best to help.



MAGNUM

TM

Magnum Tool Corp., Inc.
5600 Bonhomme Rd, Suite B
Houston, TX 77036

1 (888) 443-8889 fax (713) 781-5677

sales@magnum-tool.com

www.magnum-tool.com



MAGNUM

®

WE HANDLE IT.™

STRIKING & DEMOLITION CATALOG

2025 VERSION 25.1

**MAGNUM**TM

WE'RE ON A MISSION TO DELIVER

Hard-Hitting Value.

In 1989, Magnum Tool Corp, Inc. began its journey as a tool distributor in Houston, Texas. Aiming to leave a lasting imprint on our industry, we focused on establishing a reputation for delivering professional-grade tools and equipment at unbeatable value. At Magnum, we assembled an exceptional team that cultivated a strong network of distributors throughout the country. We are proud of the company we built, and now our loyal customers deploy our tools on jobs all over the world. Our commitment to excellence through friendly customer service, product training, and support sets Magnum apart.

Today, Magnum is known for offering a premium selection of trade tools. We continue to innovate and add value to our products, which are engineered to endure daily rugged use. Whether it is a sledgehammer, shovel, or rake, Magnum provides professional-grade equipment ensuring you hit your target.

**TM**

VISIT MAGNUM-TOOL.COM





Striking.



<i>HAMMERS</i>	4
<i>SLEDGE HAMMERS</i>	5-7
<i>AXES & SPLITTING WEDGES</i>	8-9
<i>HOES & PICSS</i>	10
<i>BIG RIG/SEMI TRUCK TOOLS</i>	11

Demolition.



<i>ROCKER PRY BARS</i>	13
<i>CROWBARS, WRECKING BARS & UTILITY BARS</i>	14-15
<i>ALIGNING BARS</i>	16
<i>SAN ANGELO BARS & POST HOLE DIGGING TOOLS</i>	17

Material Handling.



<i>SHOVELS</i>	18-19
<i>RAKES & WHEELBARROWS</i>	20-21
<i>TRASH CANS</i>	22-23
<i>DUMP CARTS</i>	24-27
<i>DUMP CART FRAMES, LIDS & ACCESSORIES</i>	28-29



<i>WARRANTY</i>	30
<i>SUPPORT</i>	31
<i>CONTACT</i>	32





CURVED CLAW



A

16 OZ.
HICKORY
SMOOTH FACE



B

FITS 16 OZ.
HICKORY
HANDLE ONLY



C

16 OZ.
FIBERGLASS
SMOOTH FACE



D

16 OZ.
SOLID STEEL
SMOOTH FACE



E

16 OZ.
STEEL SHAFT
SMOOTH FACE



RIP CLAW



F

16 OZ.
STEEL SHAFT
SMOOTH FACE



G

16 OZ.
FIBERGLASS
SMOOTH FACE



H

24 OZ.
FIBERGLASS
SERRATED FACE



DRYWALL



I

14" HANDLE
SERRATED FACE



J

16" HANDLE
SERRATED FACE

	ITEM CODE	DESCRIPTION	WEIGHT (LB)	BOX COUNT	PURCHASE UNIT
A	HAC16-W	16 OZ CURVED CLAW HAMMER W/ HICKORY HANDLE	1.5	24	1 PC
B	HDC01	2 LB 14" CLAW HAMMER REPLACEMENT HICKORY HANDLE	2	4	1 PC
C	HAC16-FY	16 OZ CURVED CLAW HAMMER W/ FIBERGLASS HANDLE & PRO SERIES GRIP	1.69	24	1 PC
D	HAC16-AS	16 OZ ALL STEEL CURVED CLAW HAMMER W/ CLASSIC GRIP	1.64	24	1 PC
E	HAC16-S	16 OZ CURVED CLAW HAMMER W/ STEEL SHAFT & CLASSIC GRIP	2	24	1 PC
F	HAAS16R	16 OZ RIP CLAW HAMMER W/ STEEL SHAFT & PERFORATED GRIP	2	24	1 PC
G	HAR16-FY	16 OZ RIP CLAW HAMMER W/ FIBERGLASS HANDLE & PRO SERIES GRIP	2	24	1 PC
H	HAF24-FY	24 OZ FRAMING HAMMER W/ FIBERGLASS HANDLE & PERFORATED GRIP, SERRATED FACE	1.63	24	1 PC
I	HAD14-S	14" DRYWALL HAMMER W/ HICKORY HANDLE, SERRATED FACE	1.39	24	1 PC
J	HAD16-S	16" DRYWALL HAMMER W/ HICKORY HANDLE, SERRATED FACE	2	24	1 PC



PRO SERIES



MAGNUM PRO SERIES FIBERGLASS SLEDGE HAMMERS

When you need a bigger hammer, reach for a PRO-SERIES. Brandishing a tough Forged Steel Head and 36" Double Injection Fiberglass Handle, these Sledge Hammers are harder than wood and with superior shock absorption. Plus, they are non-conductive when working around electricity. The comfort grip handle not only feels great but also provides a better gripping surface and reduces fatigue and slippage.

- Tougher than nails and built for daily abuse
- Fiberglass shaft with comfort grip handle
- Forged Steel Heads in multiple weights



ITEM CODE	DESCRIPTION	WEIGHT (LB)	BOX COUNT	PURCHASE UNIT
HAS6FL-D	6 LB SLEDGE HAMMER W/ 36" DOUBLE INJECTION FIBERGLASS HANDLE	8	4	1 PC
HAS8FL-D	8 LB SLEDGE HAMMER W/ 36" DOUBLE INJECTION FIBERGLASS HANDLE	10	4	1 PC
HAS10FL-D	10 LB SLEDGE HAMMER W/ 36" DOUBLE INJECTION FIBERGLASS HANDLE	12	2	1 PC
HAS12FL-D	12 LB SLEDGE HAMMER W/ 36" DOUBLE INJECTION FIBERGLASS HANDLE	11.75	2	1 PC
HAS14FL-D	14 LB SLEDGE HAMMER W/ 36" DOUBLE INJECTION FIBERGLASS HANDLE	13.6	2	1 PC
HAS16FL-D	16 LB SLEDGE HAMMER W/ 36" DOUBLE INJECTION FIBERGLASS HANDLE	18	2	1 PC
HAS20FL-D	20 LB SLEDGE HAMMER W/ 36" DOUBLE INJECTION FIBERGLASS HANDLE	22	2	1 PC





LONG HANDLE SLEDGE HAMMERS

Perfect for demolition and breaking projects, this hammer features a premium 36" hickory handle for easy gripping, control, and comfort. It also boasts a superior forged head.

- Long 36" Hickory Handle: Provides high impact resistance and added striking force
- Octagonal Design: Distributes the load evenly and equalizes stress
- Alloyed Steel Head: Press forged and heat-treated for durability
- Beveled and Machined Striking Face: Prevents accidents from metal shards

ITEM CODE	DESCRIPTION	WEIGHT (LB)	BOX COUNT	PURCHASE UNIT
HAS8V	8 LB SLEDGE HAMMER W/ 36" HICKORY HANDLE	9.37	4	1 PC
HAS10V	10 LB SLEDGE HAMMER W/ 36" HICKORY HANDLE	11.75	2	1 PC
HAS12V	12 LB SLEDGE HAMMER W/ 36" HICKORY HANDLE	13.6	2	1 PC
HAS14V	14 LB SLEDGE HAMMER W/ 36" HICKORY HANDLE	15.13	2	1 PC
HAS16V	16 LB SLEDGE HAMMER W/ 36" HICKORY HANDLE	18.26	2	1 PC
HAS20V	20 LB SLEDGE HAMMER W/ 36" HICKORY HANDLE	20.82	2	1 PC



SLEDGE HAMMER REPLACEMENT PARTS



	ITEM CODE	DESCRIPTION	WEIGHT (LB)	BOX COUNT	PURCHASE UNIT
A	HDS36A	36" BIG EYE SLEDGE HAMMER HANDLE (FOR 14-20 LB HEAD)	1.76	10	1 PC
B	HDS36B	36" SMALL EYE SLEDGE HAMMER HANDLE (FOR 6-12 LB HEAD)	2	10	1 PC
C	WESF	FLAT METAL ASSEMBLY WEDGE	0.03	500	1 PC
D	WESR	ROUND METAL ASSEMBLY WEDGE	0.03	500	1 PC



PRO SERIES



MAGNUM PRO SERIES SHORT SLEDGE HAMMERS

When you need a bigger hammer, reach for a PRO-SERIES. Brandishing a tough Forged Steel Head and 16" Fiberglass Handle, these Sledge Hammers are harder than wood with superior shock absorption. The same benefits of the 36" Sledge Hammer in a compact size.

ITEM CODE	DESCRIPTION	WEIGHT (LB)	BOX COUNT	PURCHASE UNIT
HAS3-FY16	3 LB SLEDGE HAMMER W/ 16" FIBERGLASS HANDLE	4	8	1 PC
HAS4-FY16	4 LB SLEDGE HAMMER W/ 16" FIBERGLASS HANDLE	5	8	1 PC

SHORT HICKORY SLEDGE HAMMERS

Perfect for demolition projects and breaking concrete and rocks, this tool features a premium 16" hickory handle for easy gripping, control, and comfort. It also boasts a superior forged head.

- The short 16" Hickory Wood Handle provides high impact resistance and more accurate strikes when doing rigorous work
- Octagonal Design: Distributes the load evenly and equalizes stress
- Alloyed Steel Head: Press forged and heat-treated for durability
- Beveled and Machined Striking Face: Prevents accidents from metal shards



ITEM CODE	DESCRIPTION	WEIGHT (LB)	BOX COUNT	PURCHASE UNIT
HAS4-V16	4 LB SLEDGE HAMMER W/ 16" HICKORY HANDLE	4.8	8	1 PC
HAS6-V16	6 LB SLEDGE HAMMER W/ 16" HICKORY HANDLE	7.35	4	1 PC
HAS8-V16	8 LB SLEDGE HAMMER W/ 16" HICKORY HANDLE	8.64	4	1 PC
HDS18W	#2 18" SLEDGE HAMMER HANDLE (FOR 6-12 LB HEAD)	1	10	1 PC



4 LB DRILLING HAMMER

Crafted with a tough, drop-forged steel head to withstand repeated impacts, this hammer features a genuine hickory hardwood handle for natural shock absorption and impact resistance. Perfectly balanced for precision and power, it's ideal for driving chisels, stakes, and wedges with ease. Whether chiseling stone, driving stakes into the ground, or tackling demolition work, this small but mighty hammer is built to deliver an impact every time.



ITEM CODE	DESCRIPTION	WEIGHT	BOX COUNT	PURCHASE UNIT
HAD4	4 LB DRILLING HAMMER	4.13 LB	8	1 PC





3-1/2 LB SINGLE & DOUBLE BIT AXES

Magnum 3-1/2 lb Single and Double Bit Axes are built to dominate heavy-duty woodcutting. Armed with heat-treated forged steel heads and rugged hickory handles, they deliver raw power, relentless durability, and superior shock absorption. Whether you're splitting logs or felling timber, these axes are the ultimate tools for taking on the toughest jobs.

Our Single Bit Axe is your go-to workhorse for splitting logs, chopping wood, and general cutting tasks, providing precision and power with a focused cutting edge. The flat poll on the opposite side is perfect for driving wedges or stakes, making it a versatile choice for a wide range of jobs.



Our Double Bit Axe brings balance and versatility, offering two cutting edges — one kept razor-sharp for chopping and fine work, and the other maintained duller for heavy-duty or rougher cuts. Ideal for pros and seasoned users, it lets you switch tasks without reaching for another tool, making it the ultimate axe for continuous, demanding work.

- Forged Steel Head: Heat-treated for superior strength and durability
- Hickory Handle: Genuine hardwood for natural shock absorption and lasting comfort
- Versatile Utility: Ideal for forestry, construction, landscaping, and outdoor projects
- Heavy-Duty Performance: Designed for professionals and serious woodcutters

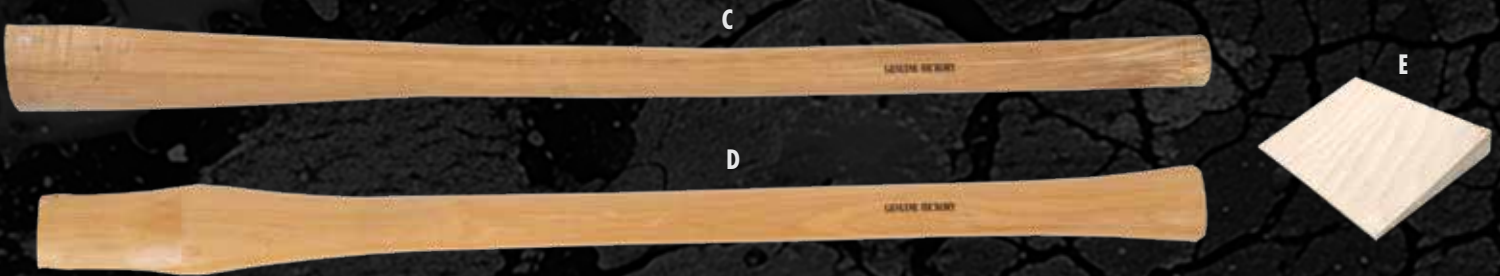

REPLACEMENT HANDLES



	ITEM CODE	DESCRIPTION	WEIGHT (LB)	BOX COUNT	PURCHASE UNIT	
	A	AXS312-V	SINGLE BIT AXE W/ HICKORY HANDLE (3-1/2 LB)	5.7	4	1 PC
	B	AXD312-V	DOUBLE BIT AXE W/HICKORY HANDLE (3-1/2 LB)	5.41	4	1 PC
	C	HDSA	36" SINGLE BIT AXE HANDLE (REPLACEMENT HANDLE ONLY)	2	20	1 PC
	D	HDDA	#2 36" DOUBLE BIT AXE HANDLE (REPLACEMENT HANDLE ONLY)	2	20	1 PC
	E	WEW02	LARGE WOOD WEDGE FOR AXE	0.02	500	1 PC



1-1/2 LB CAMP AXE

The Magnum 1.5 lb Camp Axe is your go-to weapon for the wild. Built for power and precision, its forged steel head bites deep into wood with every swing, while the genuine hickory handle absorbs shock for unbeatable control and comfort. Compact yet mighty, this axe splits kindling, chops limbs, and handles campsite duties with ease. Whether you're blazing trails or building fires, trust this rugged tool to bring the heat. Get ready to chop, split, and dominate—wherever adventure takes you.

- 1.5 lb forged steel head for powerful chopping and splitting
- Genuine hickory handle absorbs shock and provides superior control
- Compact design is easy to transport and carry
- Ideal for splitting kindling and chopping small limbs
- Built tough for lasting durability in rugged environments



ITEM CODE	DESCRIPTION	WEIGHT	BOX COUNT	PURCHASE UNIT
AXE112-V	CAMP AXE W/ HICKORY HANDLE (1-1/2 LB)	2 LB	24	1 PC

SPLITTING WEDGES

Make splitting wood, or busting through material, faster and easier with our durable splitting wedges. Available in 4 lb and 5 lb sizes, and featuring a 60-degree bevel and a forged head for efficient performance. Use it with a sledgehammer or splitting maul to quickly turn tough splitting tasks into manageable pieces. Crafted from machined, ground, and heat-treated carbon steel, this wedge is built to withstand tough, repeated use.

- Designed for splitting logs and kindling
- High tempered steel
- 4 lb and 5 lb available
- Flat black enamel finish
- Wedge design



	ITEM CODE	DESCRIPTION	WEIGHT (LB)	BOX COUNT	PURCHASE UNIT
A	WES4	4 LB SPLITTING WEDGE	4.2	6	1 PC
B	WES5	5 LB SPLITTING WEDGE	5.2	6	1 PC







HEAVY DUTY HOES WITH LONG WOODEN HANDLES

Magnum Heavy Duty Hoes are built to take on the toughest digging and cultivating tasks. The forged steel blade delivers exceptional strength for breaking through dense soil, cutting roots, and clearing debris. The long, solid wood handle provides superior leverage and natural shock absorption, reducing fatigue during extended use. Designed for durability and reliability, this tool is a must-have for serious gardeners, landscapers, and contractors alike.



- Forged steel blade for superior strength and durability
- Sturdy wooden handle offers comfort, leverage, and shock absorption
- Heavy-duty construction ideal for tough soil, roots, and debris
- Available in 2.5 lb and 3 lb models, when a larger head is needed

ITEM CODE	DESCRIPTION	WEIGHT (LB)	BOX COUNT	PURCHASE UNIT
HEH212-60	2.5 LB HEAVY DUTY HOE W/ 55" WOOD HANDLE	3.7	10	1 PC
HEH3-60	3 LB HEAVY DUTY HOE W/ 55" WOOD HANDLE	4.2	10	1 PC
 HEH212H	2.5 LB HOE HEAD ONLY (REPLACEMENT HEAD)	2.5	10	1 PC
 HEH3H	3 LB HOE HEAD ONLY (REPLACEMENT HEAD)	3	10	1 PC
 HDH55	55" X 1" HOE HANDLE ONLY (REPLACEMENT HANDLE)	1.2	10	1 PC

PICK HEADS & PICK HANDLES

Pick and choose your handle and head to build the perfect pick.



ITEM CODE	DESCRIPTION	WEIGHT (LB)	BOX COUNT	PURCHASE UNIT
A	HDP36H #6 36" HICKORY PICK HANDLE (HANDLE ONLY)	2	10	1 PC
B	HDP36FG #6 36" PRO SERIES FIBERGLASS PICK HANDLE (HANDLE ONLY)	2	10	1 PC
C	MAP5 5 LB PICK MATTOCK HEAD (HEAD ONLY)	5	5	1 PC
	MAC5 5 LB CUTTER PICK MATTOCK HEAD (HEAD ONLY)	5	5	1 PC
D	PIR6 6 LB RAILROAD PICK HEAD (HEAD ONLY)	6.6	5	1 PC



8 LB BEAD BREAKING TOOL

Easily break stubborn tire beads with this 8 lb duck-billed bead breaking wedge. Featuring a sturdy 30" hickory handle for excellent leverage and durability, this tool is perfect for heavy-duty tire work. Its duck-bill design delivers precise, efficient performance, making it a must-have for tire maintenance and repair.

- 30" Hickory Handle
- Forged Steel head for strength and ability to withstand significant force
- Breaks through concrete, asphalt, rock and more.

ITEM CODE	DESCRIPTION	WEIGHT	BOX COUNT	PURCHASE UNIT
TOB80V	8 LB BREAKING TOOL W/ 30" HICKORY HANDLE	10 LB	2	1 PC

38" TIRE IRON BAR

Made from high-quality 40Cr forged steel, this 38" x 4/5" tire bar delivers powerful leverage for quick, efficient tire changes on autos, trucks, and big rigs. Its ergonomic handle enhances comfort, while the black powder-coated finish adds durability. A versatile, cost-effective alternative to expensive equipment, it handles various tire sizes with ease and stores compactly – ideal for professionals and automotive enthusiasts alike.



ITEM CODE	DESCRIPTION	WEIGHT	BOX COUNT	PURCHASE UNIT
BATI38	38" TIRE IRON BAR, BLACK MATTE FINISH	7 LB	6	1 PC

HEAVY-DUTY DEMOLITION

When it's time to tear down, break apart, and pull through, Magnum's heavy-duty demolition tools are built to handle the hardest jobs. From ripping out walls and flooring to prying, aligning, and pulling, these power-packed tools give you the leverage, strength, and durability needed to dominate demolition work. Engineered for ultimate performance, they make short work of stubborn nails, heavy boards, and tough materials — so you can focus on building what comes next.

13



SOLUTIONS FOR

DEMOLITION

Break apart walls, floors, or other structures during renovations or demo.

REMOVAL

Extract nails or screws from wood and walls.

PRY

Separate two objects that are joined together, such as boards, panels, or pallets.

LEVERAGE

Provide leverage to lift heavy objects or materials.

ALIGN

Adjust or align heavy materials like beams or boards into place.

WRECK & PULL

Break down pallets, pull apart wooden crates, or disassemble structures.

14



15



16



17





HEAVY DUTY ROCKER PRY BARS

Engineered for maximum leverage and versatility, the Magnum Rocker Pry Bar features rugged 7/8" hex steel for a secure grip and superior strength. Its unique rocker head design allows both push and pull actions, making tough jobs feel effortless. The open claw provides easy access to tight, hard-to-reach areas, while a polished, clear-coated head enhances durability for long-lasting performance.

- Built from heavy-duty steel for ultimate strength
- Rocker head offers push-and-pull versatility for greater power
- Open claw design excels in confined spaces
- 7/8" hex stock for a comfortable, solid grip

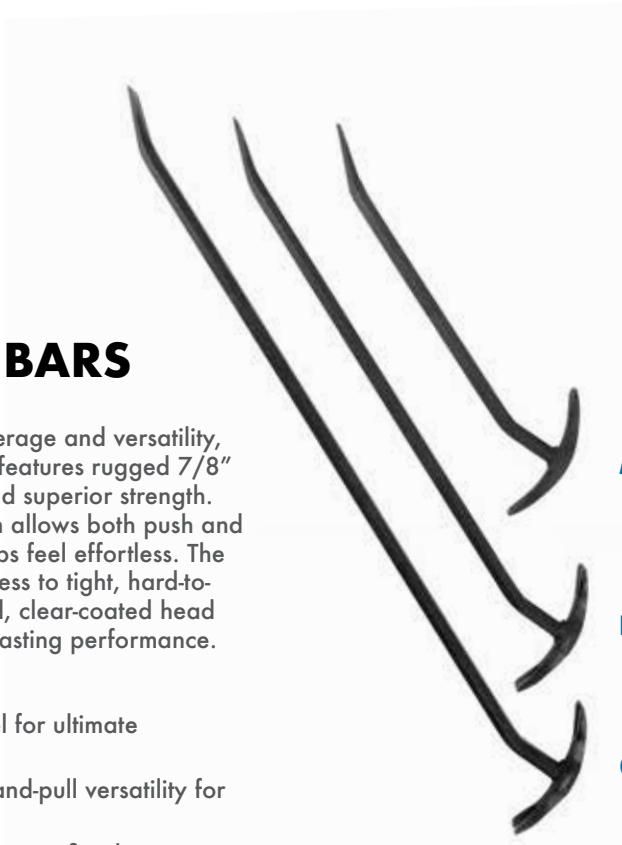

A

B

C



	ITEM CODE	DESCRIPTION	WEIGHT (LB)	BOX COUNT	PURCHASE UNIT
A	BAT24-78	24" X 7/8" HEAVY DUTY ROCKER BAR	6	N/A	1 PC
B	BAT36-78	36" X 7/8" HEAVY DUTY ROCKER BAR	9	N/A	1 PC
C	BAT48-78	48" X 7/8" HEAVY DUTY ROCKER BAR	11	N/A	1 PC





PINCH POINT CROWBARS

Built for prying and leveraging heavy objects, the Magnum Pinch Point Crowbar features hardened, drop-forged steel construction for exceptional durability that won't bend or break. Perfect for stubborn prying, heavy lifting, and breaking up hard surfaces, this heavy-duty tool is a must-have for demolition, construction, and landscaping tasks.

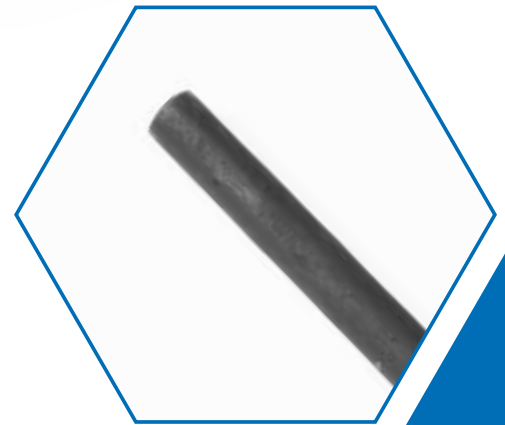

	ITEM CODE	DESCRIPTION	WEIGHT (LB)	BOX COUNT	PURCHASE UNIT
A	BAC10	PINCH POINT CROWBAR (BLACK MATTE FINISH / 10 LB, 48" X 1-1/4")	10	N/A	1 PC
B	BAC14	PINCH POINT CROWBAR (BLACK MATTE FINISH / 14 LB, 54" X 1-1/8")	14	N/A	1 PC
C	BAC18	PINCH POINT CROWBAR (BLACK MATTE FINISH / 18 LB, 60" X 1-3/8")	18	N/A	1 PC
D	BAC22	PINCH POINT CROWBAR (BLACK MATTE FINISH / 22 LB, 64" X 1-1/2")	22	N/A	1 PC

KONG WRECKING BARS

Built from high-grade forged steel, Magnum Kong Bars feature an 1-1/4" shank and an extra-wide chisel blade for maximum force. The unique bar-to-claw angle enhances leverage by over 50%. Its low-profile claw slides deep under workpieces for unmatched prying power and control. Whether pulling nails, ripping boards, or handling heavy-duty demolition, Kong isn't just a tool—it's a force of nature.



ITEM CODE	DESCRIPTION	WEIGHT (LB)	BOX COUNT	PURCHASE UNIT
BAG24	24" KONG WRECKING BAR, BLACK MATTE FINISH (24" LENGTH X 1-1/4" SHANK)	4.52	N/A	1 PC
BAG36	36" KONG WRECKING BAR, BLACK MATTE FINISH (36" LENGTH X 1-1/4" SHANK)	7.26	N/A	1 PC



GOOSENECK WRECKING BARS

The Magnum Gooseneck Wrecking Bars are built for pulling, prying, and straightening with ease. One end features an angled chisel for prying and lifting, while the opposite slotted end is ideal for pulling nails. Available in 24", 30", 36", and 48" sizes, it's finished in a durable black matte coating for corrosion and rust resistance.

- Durable hex-shaped bar with a black matte finish for added strength and corrosion resistance
- Angled chisel prying end for leverage and a nail puller for versatile demolition tasks
- Available in multiple lengths with shanks ranging from 3/4" to 1" for various applications

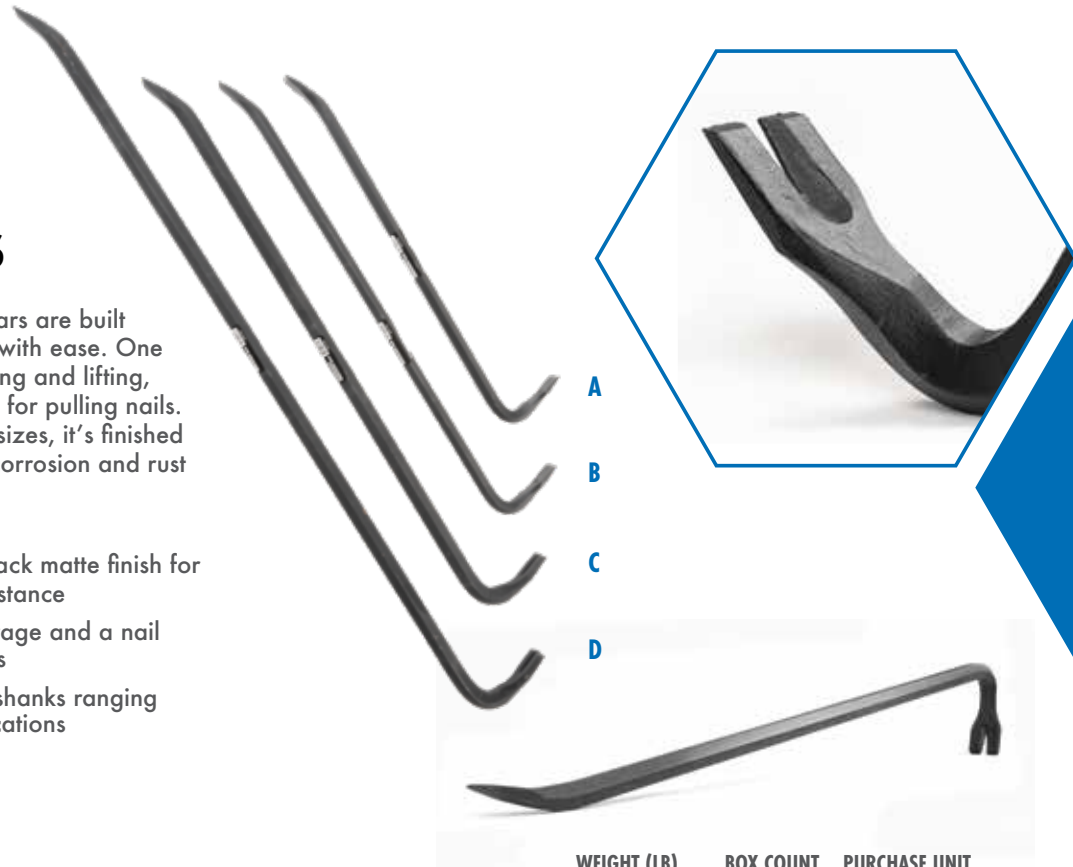

	ITEM CODE	DESCRIPTION	WEIGHT (LB)	BOX COUNT	PURCHASE UNIT
A	BAW24-34	24" X 3/4" GOOSENECK WRECKING BAR (HEX BLACK MATTE FINISH)	3	6	1 PC
B	BAW30-34	30" X 3/4" GOOSENECK WRECKING BAR (HEX BLACK MATTE FINISH)	3.44	6	1 PC
C	BAW36-1	36" X 1" GOOSENECK WRECKING BAR (HEX BLACK MATTE FINISH)	9	6	1 PC
D	BAW48-1	48" X 1" GOOSENECK WRECKING BAR (HEX BLACK MATTE FINISH)	9.17	N/A	1 PC

15" UTILITY PRY BAR

Compact yet powerful, the Magnum 15" Utility Pry Bar is the ideal multipurpose tool for prying, lifting, and scraping. Its slim, durable design provides precision and strength, making it perfect for a wide range of tasks – from pulling nails to separating materials.

- Durable and strong forged high-carbon steel to handle heavy daily abuse
- The perfect amount of leverage for pulling nails, splitting boards, lifting and scraping
- Three beveled nail slots



ITEM CODE	DESCRIPTION	WEIGHT	BOX COUNT	PURCHASE UNIT
BAW15	15" UTILITY PRY BAR (1-1/4"W X 1/4")	1 LB	24	1 PC





ALIGNING BARS

Magnum Aligning Pry Bars are a versatile tool designed for precision and durability. Featuring a rolling head and straight tapered point tip, they provide excellent leverage and alignment capabilities. Constructed from high-alloy steel with a corrosion-resistant black oxide finish, or a zinc coated finish for added corrosion resistance, these bars are built to withstand tough jobs. Durable, reliable, and efficient—this is a must-have tool for professionals.

- Available in either black matte oxide or zinc coated
- Choose from an array of lengths and diameters
- Premium quality bars that offer great strength and versatility

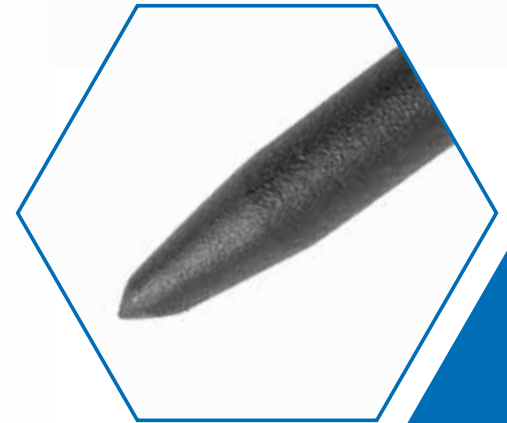

ZINC COATED

	ITEM CODE	DESCRIPTION	WEIGHT (LB)	BOX COUNT	PURCHASE UNIT
A	BAZ24-78	ALIGNING BAR (ZINC COATING FINISH / 24" X 7/8")	2	6	1 PC
	BAZ30-34	ALIGNING BAR (ZINC COATING FINISH / 30" X 3/4")	2.63	6	1 PC
B	BAZ30-78	ALIGNING BAR (ZINC COATING FINISH / 30" X 7/8")	2.63	6	1 PC
C	BAZ36-78	ALIGNING BAR (ZINC COATING FINISH / 36" X 7/8")	4.41	6	1 PC

BLACK MATTE

	ITEM CODE	DESCRIPTION	WEIGHT (LB)	BOX COUNT	PURCHASE UNIT
D	BAP12-12	ALIGNING BAR (BLACK MATTE FINISH / 12"X 1/2")	1.2	20	1 PC
E	BAP18-58	ALIGNING BAR (BLACK MATTE FINISH / 18"X 5/8")	1.7	20	1 PC
F	BAP24-34	ALIGNING BAR (BLACK MATTE FINISH / 24"X 3/4")	2.63	20	1 PC
G	BAP30-34	ALIGNING BAR (BLACK MATTE FINISH / 30"X 3/4")	4.54	6	1 PC
G	BAP36-78	ALIGNING BAR (BLACK MATTE FINISH / 36"X 7/8")	5.5	6	1 PC



SAN ANGELO BAR

Designed for maximum versatility and power. Featuring a narrow pencil point on one end for concentrated force and a chisel blade on the other, this tool is perfect for cutting, prying, and breaking through tough materials like dirt, concrete, rock, and ice. Whether you're tackling demolition or heavy-duty digging, the Magnum San Angelo Bar delivers the strength and precision you need to get the job done.



ITEM CODE	DESCRIPTION	WEIGHT	BOX COUNT	PURCHASE UNIT
BAS17-1	SAN ANGELO BAR (BLACK MATTE FINISH / 17 LB, 72" X 1")	17 LB	N/A	1 PC



POST HOLE DIGGER TAMPING BAR

Built for tough jobs, this bar is the ultimate tool for digging, loosening, and tamping. At 72" long with a 1" shank and weighing 17 lbs., this bar features a durable chisel head on one end for breaking through soil and a tamper head on the other for securely packing it back around set posts. Whether you're digging post holes, stabilizing posts, or clearing rocks from soil, this versatile tool makes hard work easier and more efficient.

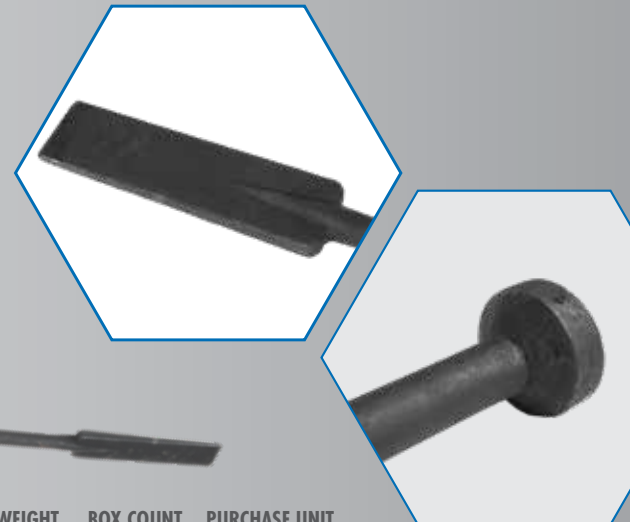

ITEM CODE	DESCRIPTION	WEIGHT	BOX COUNT	PURCHASE UNIT
BAD17-1	POST HOLE DIGGER BAR (ROUND BLACK MATTE FINISH / 17LB, 72" X 1")	17 LB	N/A	1 PC

POST HOLE DIGGER

The Magnum Post Hole Digger delivers precision and power for fence posts, deck supports, and footings. Reinforced steel blades and sturdy ashwood handles.



ITEM CODE	DESCRIPTION	WEIGHT	BOX COUNT	PURCHASE UNIT
DIP01-AH	POST HOLE DIGGER W/ ASHWOOD HANDLE	8 LB	N/A	1 PC





PRO SERIES

MAGNUM PRO SERIES LONG HANDLE FIBERGLASS SHOVELS

Tackle any job with the durability and performance of Magnum Pro Series Fiberglass Shovels. This premium lineup includes Square, Round, and Spade Shovels designed for heavy-duty use in construction, landscaping, and gardening. Engineered with robust full-tempered steel blades and lightweight industrial-grade fiberglass handles, these tools are built to last while reducing fatigue during extended tasks.

- Full-tempered steel blades with corrosion resistant finishing for superior strength and long-lasting durability
- Resilient fiberglass handles offer a lightweight, non-conductive grip for enhanced safety
- Ergonomic footstep design increases stability, leverage, and control
- Comfort grip reduces hand fatigue for maximum efficiency



	ITEM CODE	DESCRIPTION	WEIGHT (LB)	BOX COUNT	PURCHASE UNIT
A	SHL60FS-PG	PRO SERIES SQUARE SHOVEL W/ FIBERGLASS HANDLE AND STEEL INSERT	6	5	1 PC
B	SHL60FR-PG	PRO SERIES ROUND SHOVEL W/ FIBERGLASS HANDLE AND STEEL INSERT	6	5	1 PC
C	SPG66F-PG	PRO SERIES SPADE SHOVEL W/ FIBERGLASS HANDLE AND STEEL INSERT	6	5	1 PC

ASHWOOD LONG HANDLE SHOVELS

Tackle any job with the classic durability and performance of hardwood. This trusted collection, including Square, Round, Sharpshooter, and Spade Shovels, is built for heavy-duty performance in construction, landscaping, and gardening. Featuring full-tempered steel blades and premium ashwood handles, these tools combine traditional craftsmanship with modern reliability for superior control and strength.

- Full-tempered steel blades deliver exceptional durability and cutting power
- Genuine ashwood handles provide natural shock absorption and long-lasting balance
- Ergonomic wide footstep enhances stability and leverage for tough digging tasks
- Smooth varnished finish protects the handle while offering a firm grip



	ITEM CODE	DESCRIPTION	WEIGHT (LB)	BOX COUNT	PURCHASE UNIT
A	SHL48WS-AH	SQUARE SHOVEL W/ 48" ASHWOOD LONG HANDLE	3	5	1 PC
B	SHL48WR-AH	HEAVY-DUTY ROUND SHOVEL W/ 48" ASHWOOD LONG HANDLE	4	5	1 PC
C	SHS48W-AH	SHARPSHOOTER W/ 48" ASHWOOD LONG HANDLE	4	5	1 PC
D	SPGL	HANDLE GARDEN SPADE W/ 48" ASHWOOD LONG HANDLE	5	5	1 PC

D-HANDLE ASHWOOD SHOVELS

Featuring robust ash wood handles and heavy duty tempered steel blades, these tools offer superior balance, shock absorption, and long-lasting reliability. Whether digging, cutting, or leveling, these compact shovels deliver professional-grade performance with enhanced maneuverability.



- 30" Round Shovel with Straight D-Handle – Ideal for digging and cutting through tough soil
- 24" Garden Spade Shovel with Straight D-Handle – Perfect for precision edging, trenching, and transplanting
- 30" Square Point Shovel with Ergonomic D-Handle – Designed for lifting, scooping, and leveling
- 16" Digging Shovel with Ergonomic D-Handle – Excellent for close-quarter digging and fine detail work

	ITEM CODE	DESCRIPTION	WEIGHT (LB)	BOX COUNT	PURCHASE UNIT
A	SHD30WR	ROUND SHOVEL W/ 30" ASHWOOD HANDLE & STRAIGHT D-GRIP HANDLE	4	5	1 PC
B	SPGD24W	GARDEN SPADE SHOVEL W/ 24" ASHWOOD HANDLE & STRAIGHT D-GRIP HANDLE	4	5	1 PC
C	SHD30WS	SQUARE SHOVEL W/ 30" ASHWOOD & ERGONOMIC D-GRIP HANDLE	4	5	1 PC
D	SHD16WR	ROUND SHOVEL W/ 16" ASHWOOD HANDLE & ERGONOMIC D-GRIP HANDLE	2	5	1 PC
E	SHS26W	SHARP SHOOTER W/ 26" ASHWOOD HANDLE & STRAIGHT D-GRIP HANDLE	4	5	1 PC

SCOOP SHOVELS

The Magnum Scoop Shovel are available in Ash Wood or Fiberglass and each feature a D-Grip Handle for strength, comfort, and versatility. These durable shovels are perfect for handling snow, grain, mulch, and other lightweight materials, while the sturdy handles absorb shock and resist wear. The ergonomic D-grip ensures a secure, comfortable hold, providing excellent control and reduced fatigue during extended use.



- Durable and lightweight
- Absorbs shock and resists wear
- D-grip handle reduces fatigue

	ITEM CODE	DESCRIPTION	WEIGHT (LB)	BOX COUNT	PURCHASE UNIT
A	SHA14DW	#14 ALUMINUM GRAIN SCOOP SHOVEL W/ ASHWOOD D-GRIP HANDLE	4	5	1 PC
B	SHP12DFG	#12, 15" X 18" POLY SCOOP SHOVEL W/ 30" FIBERGLASS ERGONOMIC D-GRIP HANDLE	3	5	1 PC





HEAVY DUTY BOW RAKE WITH ASHWOOD HANDLE

The Magnum Bow Rake is built for tough outdoor tasks with a heat-treated 16" wide, 16-tine head and a durable ashwood handle for superior strength and shock absorption. Its heavy-duty tines efficiently rake, level, and break up soil or debris, making it a dependable choice for residential and commercial landscaping.

- Sturdy hardwood handle for strength and comfort
- Heavy-duty tines for efficient raking and leveling
- Bow style has a bit more flex than a T head rake
- Designed for durability and performance



ITEM CODE	DESCRIPTION	WEIGHT	BOX COUNT	PURCHASE UNIT
RABT-AH	70" BOW RAKE W/ 62" ASHWOOD HANDLE	4 LB	N/A	1 PC



6 CU. FT. STEEL DUAL WHEEL WHEELBARROWS

- 6 cubic feet capacity
- Dual wheels offer better balance
- Heavy-duty 12 gauge steel tray
- Reinforced tray braces
- 16" Pneumatic or Flat-free tires
- Steel or wood handles



DUAL WHEELS offer better balance when carrying heavier loads. Available in Flat-Free or Pneumatic.

ITEM CODE	DESCRIPTION	WHEEL/TIRE SIZE	LOAD CAPACITY	WEIGHT (LB)	PURCHASE UNIT
BAWH6-SHA-2	6 CU. FT. STEEL WHEELBARROW W/ DUAL PNEUMATIC TIRES (STEEL HANDLE)	16"	6 CU. FT.	55	1 PC
BAWH6-SHF-2	6 CU. FT. STEEL WHEELBARROW W/ DUAL FLAT-FREE TIRES (STEEL HANDLE)	16"	6 CU. FT.	59	1 PC
BAWH6-WHA-2	6 CU. FT. STEEL WHEELBARROW W/ DUAL PNEUMATIC TIRES (WOOD HANDLE)	16"	6 CU. FT.	53	1 PC
BAWH6-WHF-2	6 CU. FT. STEEL WHEELBARROW W/ DUAL FLAT-FREE TIRES (WOOD HANDLE)	16"	6 CU. FT.	57	1 PC



6 CU. FT. STEEL WHEELBARROWS

- 6 cubic feet capacity
- Single wheel offers better maneuvering when cornering
- Heavy-duty 12 gauge steel tray
- Reinforced tray braces
- 16" Pneumatic or Flat-free tires
- Steel or wood handles



Flat-Free

Pneumatic

WOOD

ITEM CODE	DESCRIPTION	WHEEL/TIRE SIZE	LOAD CAPACITY	WEIGHT (LB)	PURCHASE UNIT
BAWH6-SHA	6 CU. FT. STEEL WHEELBARROW W/ PNEUMATIC TIRE (STEEL HANDLE)	16"	6 CU. FT.	49	1 PC
BAWH6-SHF	6 CU. FT. STEEL WHEELBARROW W/ FLAT-FREE TIRE (STEEL HANDLE)	16"	6 CU. FT.	50	1 PC
BAWH6-WHA	6 CU. FT. STEEL WHEELBARROW W/ PNEUMATIC TIRE (WOOD HANDLE)	16"	6 CU. FT.	46	1 PC
BAWH6-WHF	6 CU. FT. STEEL WHEELBARROW W/ FLAT-FREE TIRE (WOOD HANDLE)	16"	6 CU. FT.	47	1 PC

WHEELBARROW PARTS



WHEELBARROW TIRE/WHEEL

ITEM CODE	DESCRIPTION	DIAMETER	WIDTH	WEIGHT (LB)	BOX COUNT	PURCHASE UNIT
TIAK16-BB	PNEUMATIC TIRE/WHEEL (STEEL - BLACK)	16"	4"	5.3	4	1 PC
TINK16-BC	FLAT-FREE TIRE/WHEEL (6-SPOKE METAL HUB)	16"	4"	6.4	4	1 PC

*Tires/Wheels fit both Dual Wheelbarrows and Single Wheelbarrows.

WHEELBARROW REPLACEMENT HANDLES



ITEM CODE	DESCRIPTION	SIZE	WEIGHT (LB)	PURCHASE UNIT
HDWB	WHEELBARROW HANDLE, WOOD	59" X 1-1/2" X 1-3/4"	3.2	1 PC
BAWH6-P3	WHEELBARROW HANDLE, STEEL	59" X 1-1/2" X 1-1/2"	4.4	1 PC





TRASH CANS

PRO SERIES

TRASH CANS

Excellent quality, innovative features and outstanding value without sacrificing durability. Welcome to Pro Series - professional grade equipment that works hard and stands up to daily punishment.

- Air channels reduce suction and make bag removal a breeze
- Built-in bag cinches to secure liner
- Massively reinforced, jobsite ready trash cans
- Ergonomic built-in handles for comfort and easy handling
- Lids and dollies available as optional accessories



MAXIMIZE AIRFLOW

FOR CAN STACKING & BAG RELEASE

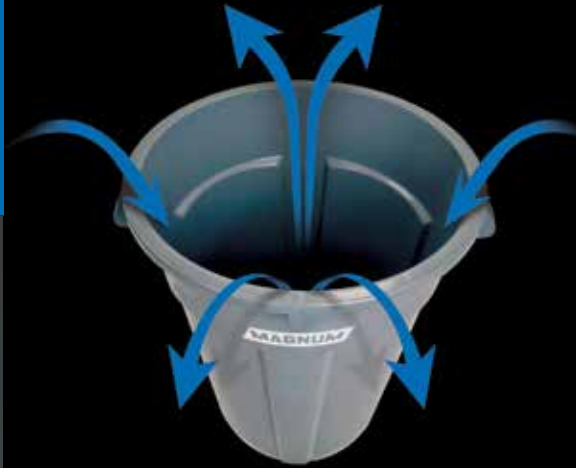

AIR CHANNELS

make removing bags and unstacking trash cans a breeze, not a challenge.



BAG CINCHES

help secure your bag and reduce clean up of messy debris.



MASSIVE REINFORCEMENT

for added strength, durability and longevity.



NEW COLORS & SIZES SEE PG. 23



PRO SERIES

MAGNUM PRO SERIES TRASH CANS

Designed to enhance productivity and reduce strain, Magnum Pro Series Trash Cans feature innovative air channels that make lifting liners effortless. Built from premium materials, they withstand even the harshest commercial environments and punishments.

- Integrated cinches secure liners without knots for fast, hassle-free changes
- Reinforced, easy-grip handles resist tearing and damage under heavy loads
- Durable reinforced base stands up to dragging over rough surfaces for extended life
- Contoured base handles improve ergonomics and reduce strain when emptying
- Rib-structured rim adds strength to resist crushing
- Stackable design allows for easy nesting, transport, and storage



ITEM CODE	DESCRIPTION	DIMENSIONS	WEIGHT (LB)	PALLET COUNT	PURCHASE UNIT
CMTC-C-32G	32 GALLON PRO SERIES TRASH CAN, GRAY	26" X 22" X 28"	9	48	1 CAN
CMTC-C-32Y	32 GALLON PRO SERIES TRASH CAN, YELLOW	26" X 22" X 28"	9	48	1 CAN
CMTC-C-32R	32 GALLON PRO SERIES TRASH CAN, RED	26" X 22" X 28"	9	48	1 CAN
CMTC-C-44G	44 GALLON PRO SERIES TRASH CAN, GRAY	28" X 24" X 31"	11	48	1 CAN
CMTC-C-55G	55 GALLON PRO SERIES TRASH CAN, GRAY	30" X 27" X 33"	14	48	1 CAN
CMTC-C-55Y	55 GALLON PRO SERIES TRASH CAN, YELLOW	30" X 27" X 33"	14	48	1 CAN
CMTC-C-55R	55 GALLON PRO SERIES TRASH CAN, RED	30" X 27" X 33"	14	48	1 CAN

TRASH CAN LIDS

- Excellent fit
- Snaps securely and opens easily
- Available in multiple sizes & colors



ITEM CODE	DESCRIPTION	WEIGHT (LB)	BOX COUNT	PURCHASE UNIT
CMTC-L-32G	32 GAL LID, GRAY	2	10	1 LID
CMTC-L-32Y	32 GAL LID, YELLOW	2	10	1 LID
CMTC-L-32R	32 GAL LID, RED	2	10	1 LID
CMTC-L-44G	44 GAL LID, GRAY	2	10	1 LID
CMTC-L-55G	55 GAL LID, GRAY	3.2	10	1 LID
CMTC-L-55Y	55 GAL LID, YELLOW	3.2	10	1 LID
CMTC-L-55R	55 GAL LID, RED	3.2	10	1 LID

HEAVY DUTY TRASH DOLLY

CATC-DG-HD

- Massively reinforced
- Universal fitment on most major brands, including Magnum Pro Series Trash Cans
- Fits 20, 32, 44, and 55 Gallon Trash Cans
- 6.2 LB





PREMIUM DUMP CARTS

- Premium injection molded tubs for added strength in corners and industrial strength durability
- Smooth surface is easy to clean and resists corrosion
- Fits through standard doorways and elevators
- Handling can be performed by a single user
- Premium grade wheels and casters, available in Heavy Duty and Non-Marking





MAGNUM™

Save freight and space by stacking more on a pallet.

1/2 CUBIC YARD DUMP CARTS

Premium built for efficient material handling and ultimate durability. Ideal for industrial and commercial use. Easy maneuverability, 700 LB load capacity, and your choice of premium wheels and casters.

750 LB LOAD CAPACITY

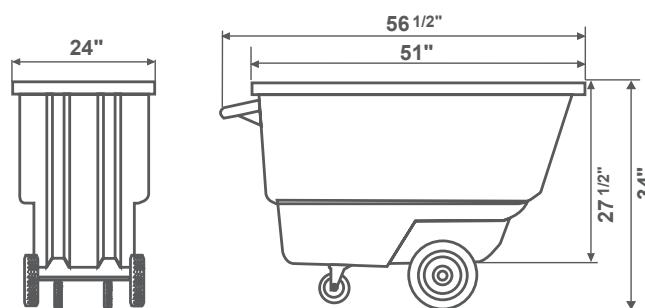

ITEM CODE	MATERIAL CAPACITY	CASTER TYPE	WHEEL TYPE	WEIGHT (LB)	PALLET COUNT
DUC12T	1/2 CU. YD.	4" HEAVY-DUTY	10" HEAVY-DUTY	64	14
DUC12T-NM*	1/2 CU. YD.	5" NON-MARKING	12" NON-MARKING	48	14

*Use 2-5/8" Axle (DUA12-575)



Lids and parts available. See pages 28-29.

1 CUBIC YARD COVERED CAPACITY DUMP CARTS

Premium built for efficient material handling and ultimate durability. Ideal for industrial and commercial use. Easy maneuverability, 800 LB load capacity, and your choice of premium wheels and casters.

800 LB LOAD CAPACITY

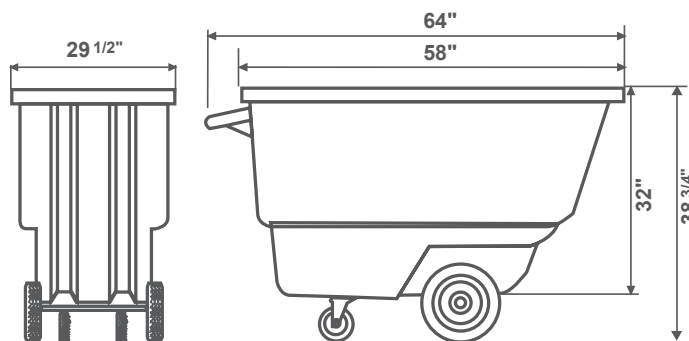

ITEM CODE	MATERIAL CAPACITY	CASTER TYPE	WHEEL TYPE	WEIGHT (LB)	PALLET COUNT
DUC100-12	1 CU. YD. COVERED CAPACITY	5" HEAVY-DUTY	12" HEAVY-DUTY	89	12
DUC100-12-NM	1 CU. YD. COVERED CAPACITY	5" NON-MARKING	12" NON-MARKING	73	12





1 CUBIC YARD COVERED CAPACITY DUMP CARTS WITH REINFORCING FRAME

Built for superior durability and efficient material handling, this premium tilt truck is perfect for industrial and commercial use. With a load capacity of up to 1,000 LB on heavy-duty casters or 900 LB with non-marking wheels, it offers smooth maneuverability and reliable performance.

UP TO 1,000 LB LOAD CAPACITY

The **reinforcing frame** provides extra structural support for safe tilting and dumping, while the lower handle offers a secure grip for controlled unloading.



ITEM CODE	CASTER TYPE	WHEEL TYPE	LOAD CAPACITY (LB)	WEIGHT (LB)	PALLET COUNT
DUC100-R	5" HEAVY-DUTY	12" HEAVY-DUTY	1000	94	12
DUC100-R-NM	5" NON-MARKING	12" NON-MARKING	900	78	12



Lids and parts available. See pages 28-29.

1 CUBIC YARD COVERED CAPACITY DUMP CARTS WITH HEAVY DUTY FULL FRAME

Engineered for heavy-duty industrial and commercial use, this premium full-frame tilt truck delivers unmatched durability and performance. With a load capacity of up to 1,200 lbs on heavy-duty casters or 950 lbs with non-marking wheels, it handles the toughest jobs with ease.

UP TO 1,200 LB LOAD CAPACITY

The **heavy-duty full frame** design reinforces the entire tub, preventing bowing or distortion under heavy loads and ensuring long-lasting reliability. A lower handle provides a secure grip for safe and controlled unloading, making this the ultimate solution for demanding material handling tasks.



ITEM CODE	CASTER TYPE	WHEEL TYPE	LOAD CAPACITY (LB)	WEIGHT (LB)	PALLET COUNT
DUC100-H	5" HEAVY-DUTY	12" HEAVY-DUTY	1200	112	10
DUC100-H-NM	5" NON-MARKING	12" NON-MARKING	950	96	10



Lids and parts available. See pages 28-29.



FORKLIFT READY DUMP CARTS

UP TO 1,250 LB LOAD CAPACITY



FORKLIFT READY DUMP CARTS

Available in both 1/2 cubic yard and 1 cubic yard covered capacity models, Magnum Forklift Ready Dump Carts are built for serious material handling with a reinforced forkliftable frame and up to 1,250 lb load capacity. Designed for industrial strength and durability, they make transporting and dumping heavy loads safe and efficient with a forklift, or without. Ideal for bulk materials, debris, or waste, these carts deliver top performance and easy maneuverability for the toughest jobs.



ITEM CODE	DESCRIPTION	LOAD CAPACITY (LB)	CASTER TYPE	WHEEL TYPE	WEIGHT (LB)	PALLET COUNT
DUC12T-F	1/2 CU. YD. FORKLIFT READY DUMP CART, HD	850	5" HEAVY-DUTY	12" HEAVY-DUTY	79	8
DUC12T-F-NM	1/2 CU. YD. FORKLIFT READY DUMP CART, NM	850	5" NON-MARKING	12" NON-MARKING	63	8
DUC100-F	1 CU. YD. COVERED CAPACITY FORKLIFT READY DUMP CART, HD	1250	5" HEAVY-DUTY	12" HEAVY-DUTY	103	7
DUC100-F-NM	1 CU. YD. COVERED CAPACITY FORKLIFT READY DUMP CART, NM	1000	5" NON-MARKING	12" NON-MARKING	87	7





DUF100R

Reinforcing Frame for 1 Cubic Yard Covered Capacity Dump Cart

Add to any existing 1 CU. YD. Covered Capacity Dump Cart. No additional hardware needed.



ITEM WEIGHT
5 LB

PURCHASE UNIT
1 FRAME

DUF100H

Heavy Duty Frame for 1 Cubic Yard Covered Capacity Dump Cart

Add to any existing 1 CU. YD. Covered Capacity Dump Cart. No additional hardware needed.



ITEM WEIGHT
23 LB

PURCHASE UNIT
1 FRAME

DUF12F-K

Forklift Ready Frame Kit for 1/2 Cubic Yard Dump Cart

Includes: (1) Forklift Ready Frame, (2) Heavy-Duty 5" Casters, (2) Heavy-Duty 12" Wheels and (1) DUA12-575 Axle.



ITEM WEIGHT
18 LB

PURCHASE UNIT
1 FRAME

DUF100F

Forklift Ready Frame for 1 Cubic Yard Covered Capacity Dump Cart

Add to any existing 1 CU. YD. Covered Capacity Dump Cart. No additional hardware needed.



ITEM WEIGHT
21 LB

PURCHASE UNIT
1 FRAME

DUMP CART LIDS & ACCESSORIES

DUMP CART FABRIC LIDS



DUL12T-F

Soft Fabric Lid for Magnum 1/2 Cubic Yard Dump Cart

DIMENSIONS 51" X 29" X 6.75"
ITEM WEIGHT 3.50 LB

DUL-F

Universal Soft Fabric Lid for 1 Cubic Yard Covered Capacity Dump Cart

DIMENSIONS 67" X 29" X 6.75"
ITEM WEIGHT 3.75 LB

DUL100-F

Soft Fabric Lid for Magnum 1 Cubic Yard Covered Capacity Dump Cart

DIMENSIONS 55" X 29" X 6.75"
ITEM WEIGHT 3.70 LB



DUMP CART PLASTIC LIDS

Plastic Lid for 1/2 Cubic Yard Dump Cart

DUL12T

ITEM WEIGHT	12 LB
PURCHASE UNIT	1 LID

Plastic Lid for 1 Cubic Yard Covered Capacity Dump Cart

DUL100

ITEM WEIGHT	17 LB
PURCHASE UNIT	1 LID

DUMP CART AXLES



ITEM CODE	WORKS WITH	AXLE LENGTH	WEIGHT (LB)	BOX COUNT	PURCHASE UNIT
DUA12-550	1/2 CU. YD. CART	21-5/8"	3	1	1 AXLE
DUA12-575*	1/2 CU. YD. CART	22-5/8"	3.3	1	1 AXLE
DUA100-12	1 CU. YD. COVERED CAPACITY CART	24-3/8"	4	1	1 AXLE

*Use this axle on 1/2 cubic yard dump carts (DUC12T-NM and DUC12T-F) when using 5" non-marking casters (CAS5PS-NM) & 12" non-marking wheels (CAS12-NM).

DUMP CART PLATE CASTERS



ITEM CODE	CASTER TYPE	WHEEL DIAMETER	WHEEL WIDTH	WEIGHT (LB)	BOX COUNT	PURCHASE UNIT
CAS4PS	HEAVY-DUTY	4"	2"	4	20	1 CASTER
CAS5PS	HEAVY-DUTY	5"	2"	4.6	10	1 CASTER
CAS5PS-NM	NON-MARKING	5"	2"	4.2 LB	10	1 CASTER

DUMP CART WHEELS



ITEM CODE	WHEEL TYPE	WHEEL DIAMETER	WHEEL WIDTH	WEIGHT (LB)	BOX COUNT	PURCHASE UNIT
CAS10	HEAVY-DUTY	10"	2-3/4"	7	2	1 WHEEL
CAS12	HEAVY-DUTY	12"	3"	11	2	1 WHEEL
CAS12-NM	NON-MARKING	12"	3"	3 LB	2	1 WHEEL





ROCK-SOLID WARRANTY.

Rest assured that your purchase of Magnum products is safe with the included one-year limited warranty. The Magnum Tool Corp., Inc. warranty protects against manufacturing defects from the date of purchase for an entire year. See warranty card for details and restrictions.



ROCK-STAR SUPPORT.

Magnum has a strong network of supportive dealers and knowledgeable Territory Managers across the United States, Canada, and internationally. Our friendly Customer Service team is based in Houston, TX, and available to assist you from 8:00 AM to 4:30 PM CST, Monday through Friday.

Find a dealer near you or contact our Customer Service team directly with any questions. We're here to help you thrive.



MAGNUM

TM

Magnum Tool Corp., Inc.
5600 Bonhomme Rd, Suite B
Houston, TX 77036

1 (888) 443-8889 fax (713) 781-5677

sales@magnum-tool.com

www.magnum-tool.com



TM

ACOUSTICAL CEILING

WIRE

& CEILING FASTENERS

Since 1989, Magnum has been manufacturing quality hanger wire for acoustical ceilings. Magnum offers Hot-Dip, and ASTM Hot-Dip, zinc coated galvanized steel wire and has options in stainless steel. Magnum's selection of 8g, 9g and 12g wire can be cut to custom lengths and pre-tied to Magnum ceiling fasteners or customer supplied fasteners. Magnum stocks 12 gauge wire in a variety of lengths between 4.33 and 20 ft with limited quantities of 16 and 30 ft wire. For longer lengths, straight wire is offered in bundles of 100 pieces or 50 pounds. ASTM and stainless steel specialty wire is stocked in 12 and 20 ft lengths, however Magnum can cut the wire to meet an order's specifications. (Please see the table on page 2 for more details.) Additionally, Magnum offers "pre-tie" services where Magnum or customer supplied fasteners are tied to the wire prior to shipping. Magnum deploys a certified 3-loop hospital tie to each fastener. (Please see the back page for a full roster of Magnum Tool Eye Lag Screws and Ceiling Clips.) If you have any additional questions about our products please contact us and we will be happy to assist you.



TM

PREPAID FREIGHT & LOCAL DELIVERY

12 Gauge Prepaid freight (20' length wire and under):

- Mixed lengths prepaid in 2,500 lb increments.
- Identical lengths prepaid in full crate quantities. (See chart)
- Shipped in metal crates- flat, bowed or coiled depending on length.
- Longer wire is shipped under tension and may retain a bend. Release tension and store flat as soon as possible after receipt.
- "Add-ons" such as dump carts, material carts, etc. can be shipped with wire. Size restrictions may apply.
- Custom pallets may be available at additional costs and lead times. Contact us for details.

Local hot-shot delivery by truck available for all wire lengths.



STRAIGHT WIRE



Choose the right straight wire based on job specifications and application. Different coating methods provide thicker or thinner layers of zinc measured in grams per meter². Hot-Dip galvanizing provides much better and more consistent corrosion resistance than electrogalvanization. ASTM hot-dip galvanizing adheres coating standards set by the American Society for Testing and Materials. Stainless steel doesn't require a coating due to its corrosion resistant properties, though it is also not as pliable as galvanized steel.

WIRE TYPE	GALVANIZED STEEL W/ ZINC COATING			STAINLESS STEEL
	WER ELECTROGALVANIZED ~ 40 grams/meter ²	WIR HOT-DIP 65 grams/meter ²	WAR ASTM HOT-DIP 85 grams/meter ²	WIS STAINLESS STEEL
GAUGE	Special Order	12g	8, 9 & 12g	12g
LENGTH	Request Quote	4', 6', 8', 10', 12', 20', 30'	12' & 20'	12' & 20'
BUNDLE	100pc bundles are standard. Select wire available in 50lb bundles.			

STRAIGHT WIRE ITEM CODE MATRIX:

WIRE TYPE	GAUGE	LENGTH IN FEET	BUNDLE SIZE
WIR	12	12	50

EXAMPLE ITEM CODE:

WIR12-12-50

Hot-Dip Straight Wire, 12 gauge, 12ft, 50lb/bundle

STANDARD STRAIGHT WIRE

Stocked, Straight Wire.

WIR Hot-Dip 12 gauge wire is our standard straight wire. Lengths of 4.33', 6', 8', 10', 12', 20' and 30' are typically in-stock and ready to ship. Contact us for real time inventory and availability of all wire types.

Hot-Dip 12g Straight Wire

ITEM CODE	WIRE LENGTH	BUNDLE SIZE	BUNDLE WEIGHT	FULL CRATE COUNT (BUNDLES)
WIR12-413-100	4.33 FT	100 PC	13 LB	150
WIR12-6-100	6 FT	100 PC	18 LB	120
WIR12-8-100	8 FT	100 PC	24 LB	100
WIR12-10-100	10 FT	100 PC	30 LB	70
WIR12-12-100	12 FT	100 PC	36 LB	70*
WIR12-20-100	20 FT	100 PC	60 LB	30*
WIR12-12-50	12 FT	50 LB	50 LB	60*
WIR12-20-50	20 FT	50 LB	50 LB	30*

ASTM Hot-Dip 9g Straight Wire

ITEM CODE	WIRE LENGTH	BUNDLE WEIGHT	FULL CRATE COUNT (BUNDLES)
WAR9-4-100	4 FT	24 LB	100
WAR9-6-100	6 FT	35 LB	70
WAR9-8-100	8 FT	47 LB	N/A**
WAR9-10-100	10 FT	59 LB	N/A**
WAR9-12-100	12 FT	70 LB	N/A**
WAR9-20-100	20 FT	118 LB	N/A**

ASTM Hot-Dip 8g Straight Wire

ITEM CODE	WIRE LENGTH	BUNDLE WEIGHT	FULL CRATE COUNT (BUNDLES)
WAR8-4-100	4 FT	27 LB	90
WAR8-6-100	6 FT	41 LB	60
WAR8-8-100	8 FT	55 LB	N/A**
WAR8-10-100	10 FT	69 LB	N/A**
WAR8-12-100	12 FT	82 LB	N/A**
WAR8-20-100	20 FT	137 LB	N/A**

* Longer 12 gauge wire has different prepaid freight polices. Contact us for details.

** Longer 9 and 8 gauge wire cannot ship in standard metal crates. All quotes for longer 8 or 9 gauge are FOB Houston. Contact us for shipping estimates and options.



PRE-TIED WIRE



Pre-Tied Wire is Magnum stock wire that is “pre-tied” with a variety of acoustical ceiling fasteners. Pre-Tied Wire can be purchased with Magnum Eye Lag Screws, Ceiling Clips, or tied with customer supplied fasteners. All Magnum “pre-ties” are certified 3 loop hospital ties, defined as 3 complete loops within 1”. Pre-Tied Wire is sold in 100-piece bundles. Custom Double-Tied Wire is available in 200-piece bundles. For expeditious delivery, we stock Standard Pre-Tied Wire in our most popular configurations.



	GALVANIZED STEEL W/ ZINC COATING			STAINLESS STEEL
WIRE TYPE	WEW ELECTROGALVANIZED ~ 40 grams/meter ²	WIW HOT-DIP 65 grams/ meter ²	WAW ASTM HOT-DIP 85 grams/ meter ²	WSW STAINLESS STEEL
GAUGE	Special Order	12g	8, 9 & 12g	12g
LENGTH	Request Quote	4', 6', 8', 10', 12', 20'	12' & 20'	12' & 20'
BUNDLE	Pre-Tied 100pc bundles are standard. Double-Tied 200pc bundles available.			

PRE-TIED WIRE ITEM CODE MATRIX:

WIRE TYPE	GAUGE	LENGTH IN FEET	CLIP/PIN CODE	=
WIW	12	20	332	

(Find codes on back page)

EXAMPLE ITEM CODE:

WIW12-20-332

Hot-Dip Pre-Tied Wire, 12 gauge, 20ft, w/ 1-1/4" Pin/Ceiling Clip, 100pc/bundle

STANDARD PRE-TIED WIRE

Stocked, Pre-Assembled, Pre-Tied Wire.

WIW Hot-Dip 12 gauge wire in lengths of 4', 6', 8', 10' and 12' “pre-tied” with our most popular 1" and 1-1/4" Pin/Ceiling Clips are standard. Contact us for real time inventory and availability of Pre-Tied wire types and custom options.

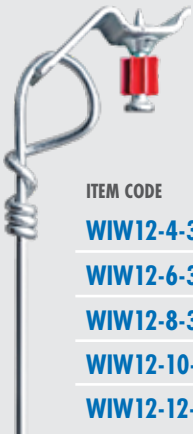

Hot-Dip 12g Pre-Tied Wire w/ 1" Pin/Ceiling Clip

ITEM CODE	WIRE LENGTH	BUNDLE SIZE	BUNDLE WEIGHT	FULL CRATE COUNT (BUNDLES)
WIW12-4-325	4 FT	100 PC	16 LB	150
WIW12-6-325	6 FT	100 PC	21 LB	120
WIW12-8-325	8 FT	100 PC	27 LB	100
WIW12-10-325	10 FT	100 PC	33 LB	70
WIW12-12-325	12 FT	100 PC	39 LB	60



Hot-Dip 12g Pre-Tied Wire w/ 1-1/4" Pin/Ceiling Clip

ITEM CODE	WIRE LENGTH	BUNDLE SIZE	BUNDLE WEIGHT	FULL CRATE COUNT (BUNDLES)
WIW12-4-332	4 FT	100 PC	16 LB	150
WIW12-6-332	6 FT	100 PC	21 LB	120
WIW12-8-332	8 FT	100 PC	27 LB	100
WIW12-10-332	10 FT	100 PC	33 LB	70
WIW12-12-332	12 FT	100 PC	39 LB	60

NEED CUSTOM PRE-TIED WIRE?

Have us pre-tie or double-tie your fasteners or Magnum fasteners.

See back page.



PREPAID FREIGHT & SHIPPING

Prepaid freight, competitive shipping rates and local delivery available.

See front page.

EYE LAG SCREWS

SCSP234T112



SCSP314T2

SCSD2T34S

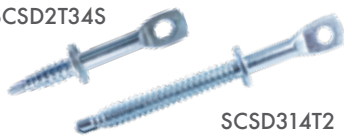

SCSD314T2

SCW3



SCW4



SCW5



ITEM CODE	EYE LAG SCREW TYPE	THREAD LENGTH	TOTAL LENGTH	BOX WEIGHT	BOX COUNT	PALLET COUNT	CLIP/PIN CODE
SCSP234T112-100	LONG SELF-TAPPING SHARP POINT	1-1/2"	2-3/4"	2.6 LB	100 PC	N/A	SCSP234T112
SCSP234T112-1000	LONG SELF-TAPPING SHARP POINT	1-1/2"	2-3/4"	27 LB	1000 PC	48 BOX	
SCSP314T2-100	LONG SELF-TAPPING SHARP POINT	2"	3-1/4"	2.8 LB	100 PC	N/A	SCSP314T2
SCSP314T2-1000	LONG SELF-TAPPING SHARP POINT	2"	3-1/4"	29 LB	1000 PC	48 BOX	
SCSD2T34S-100	SELF-DRILLING	3/4"	2"	1.7 LB	100 PC	N/A	SCSD2T34
SCSD2T34S-1000	SELF-DRILLING	3/4"	2"	18 LB	1000 PC	48 BOX	
SCSD314T2-100	SELF-DRILLING	2"	3-1/4"	2.9 LB	100 PC	N/A	SCSD314T2
SCSD314T2-1000	SELF-DRILLING	2"	3-1/4"	30 LB	1000 PC	48 BOX	
SCW3-100	WOOD	1-1/2"	3"	2.1 LB	100 PC	N/A	W3
SCW3-1000	WOOD	1-1/2"	3"	22 LB	1000 PC	100 BOX	
SCW4-100	WOOD	1-1/2"	4"	2.9 LB	100 PC	N/A	W4
SCW4-1000	WOOD	1-1/2"	4"	30 LB	1000 PC	60 BOX	
SCW5-100	WOOD	1-1/2"	5"	3.8 LB	100 PC	N/A	W5
SCW5-1000	WOOD	1-1/2"	5"	39 LB	1000 PC	60 BOX	

CEILING CLIPS

CLA90



CLV4



CLZ3



CLAS325



CLAS332



BOT144-100



ITEM CODE	DESCRIPTION	BOX WEIGHT	BOX COUNT	CASE COUNT	PURCHASE UNIT	CLIP/PIN CODE
CLA90	90 DEGREE ANGLE CLIP	27.5 LB	1000 PC	5 BOX	1 BOX	90
CLV4	4-1/4" VERTICAL BAR JOIST CLIP (1000)	47 LB	1000 PC	N/A	1 BOX	V4
CLV4-100	4-1/4" VERTICAL BAR JOIST CLIP (100)	4.7 LB	100 PC	N/A	1 BOX	
CLZ3	2-7/8" Z-PURLIN CLIP (1000)	43 LB	1000 PC	N/A	1 BOX	Z3
CLZ3-100	2-7/8" Z-PURLIN CLIP (100)	4.3 LB	100 PC	N/A	1 BOX	
CLAS325	POWDER ACTUATED CEILING CLIP W/ 1" PIN (1000)	33 LB	1000 PC	N/A	1 BOX	325
CLAS325-100	POWDER ACTUATED CEILING CLIP W/ 1" PIN (100)	3.3 LB	100 PC	N/A	1 BOX	
CLAS332	POWDER ACTUATED CEILING CLIP W/ 1-1/4" PIN (1000)	35 LB	1000 PC	N/A	1 BOX	332
CLAS332-100	POWDER ACTUATED CEILING CLIP W/ 1-1/4" PIN (100)	3.5 LB	100 PC	N/A	1 BOX	
BOT144-100	1/4"-20 X 4-1/4" TOGGLE BOLT (ZINC-PLATED)	8.75 LB	100 PC	5 BOX	1 BOX	144

